

# X30 125cc RL-C TAG

		FEATURES - CARACTERISTIQUES	
		Cylinder volume <i>Volume du cylindre</i>	123.67 cm <sup>3</sup>
		Bore <i>Alésage</i>	54 mm
		Max. bore <i>Alésage max.</i>	54.28 mm
		Stroke <i>Course</i>	54 mm
		Cooling system <i>Système de refroidissement</i>	Water <i>À Eau</i>
		Inlet system <i>Système d' admission</i>	Reed valve <i>À clapets</i>
		Cylinder / crankcase transfers n° <i>N° de canaux cylindre / carter</i>	3 / 3
Carburetor Tillotson <i>Carburateur Tillotson</i>	HW-27A (Ø27 Venturi)	Inlet / exhaust ports number <i>N° lumières admiss. / échapp.</i>	3 / 3
Number of piston rings <i>Nombre de segments</i>	1	Combustion chamber shape <i>Forme chambre de combustion</i>	Spherical <i>Sphérique</i>
Big end conr. bearing diam. <i>Diamètre roulement tête de bielle</i>	20x26x15	Selettra or PVL ignition <i>Allumage Selettra ou PVL</i>	Digital
Crankshaft bearing diam. <i>Diamètre roulement du vilebrequin</i>	30x62x16	Distance between conrod centers <i>Longueur (entraxe) de la bielle</i>	102 mm
Small end conr. bearing diam. <i>Diamètre roulement pied de bielle</i>	14x18x17.5	RPM limiter <i>Limiteur de régime</i>	Yes <i>Oui</i>
Balancing shaft <i>Arbre d'équilibrage</i>	Yes <i>Oui</i>	Electric starter <i>Démarrreur électrique</i>	Yes <i>Oui</i>

DESCRIPTION OF THE MATERIAL DESCRIPTION DES MATERIAUX		PISTON	
Conrod material <i>Matériau de la bielle</i>	Steel <i>Acier</i>	 <p>Piston min. weight (ring incl.) 128 g Poids min. piston (avec segment) 128g</p>	
Crankshaft material <i>Matériau du vilebrequin</i>	Steel <i>Acier</i>		
Balancing shaft material <i>Matériau de l'arbre d'équilibrage</i>	Steel <i>Acier</i>		
Gears material <i>Matériau des engrenages</i>	Steel <i>Acier</i>		
Starter ring material <i>Matériau de la couronne démarreur</i>	Steel <i>Acier</i>		
Head material <i>Matériau de la culasse</i>	Aluminium		DISTANCE BETWEEN CONROD CENTERS ENTRAXE DE LA BIELLE
Cylinder material <i>Matériau du cylindre</i>	Aluminium	 <p>Min. weight 110 g Poids min. 110 g</p>	
Liner material <i>Matériau de la chemise</i>	Iron <i>Fonte</i>		
Crankcase material <i>Matériau du carter</i>	Aluminium		
Piston material <i>Matériau du piston</i>	Aluminium		
Piston rings material <i>Matériau des segments</i>	Iron <i>Fonte</i>		
Exhaust muffler material <i>Matériau du pot d'échappement</i>	Sheet-steel <i>Tôle acier</i>		
Ball-bearings <i>Roulements</i>	Type 6206		
CRANKSHAFT - VILEBREQUIN			BALANCING SHAFT ARBRE D'EQUILIBRAGE
 <p>Piston pin min. weight 28 g Poids min. axe de piston 28 g</p> <p>Crankpin min. weight 116 g Poids min. axe de vilebrequin 116 g</p> <p>Bearing Seat Distance Distance du siège de roulement</p> <p>Complete crankshaft min. weight 2150 g Poids min. du vilebrequin complet 2150 g</p>			 <p>Min. weight 315 g Poids Min. 315 g</p>
			CRANKSHAFT BALL BEARINGS ROULEMENTS À BILLES DU VILEBREQUIN
			

DIMENSIONS OF ALTERNATIVE CRANKSHAFT WITH ROLLER MAIN BEARINGS  
 DIMENSIONS DU VILEBREQUIN ALTERNATIF AVEC ROULEMENTS A ROULEAUX

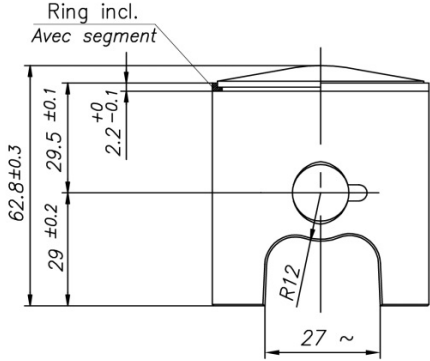
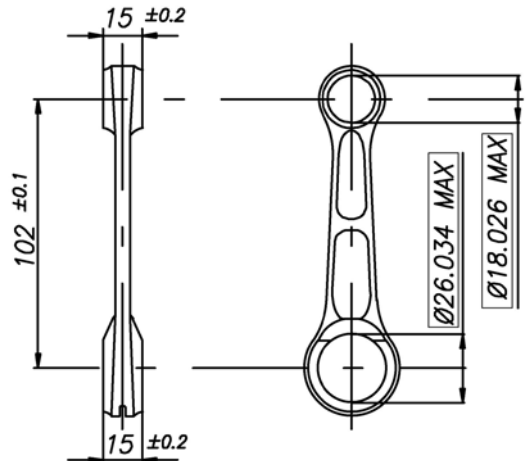
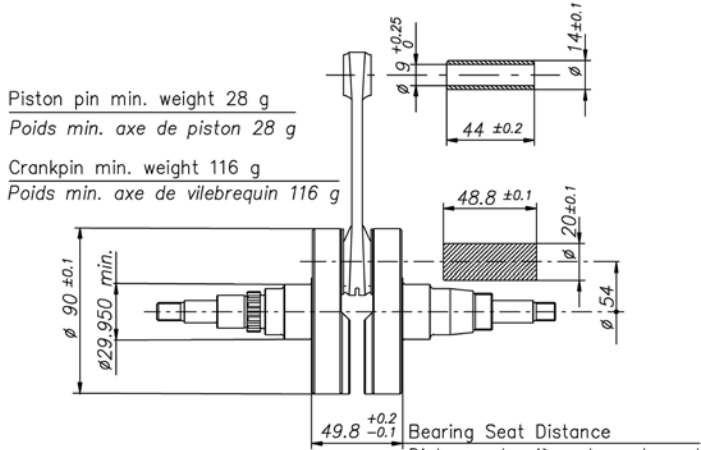
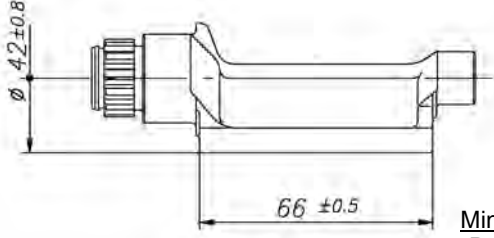
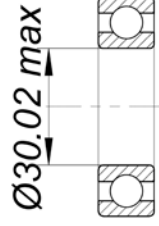
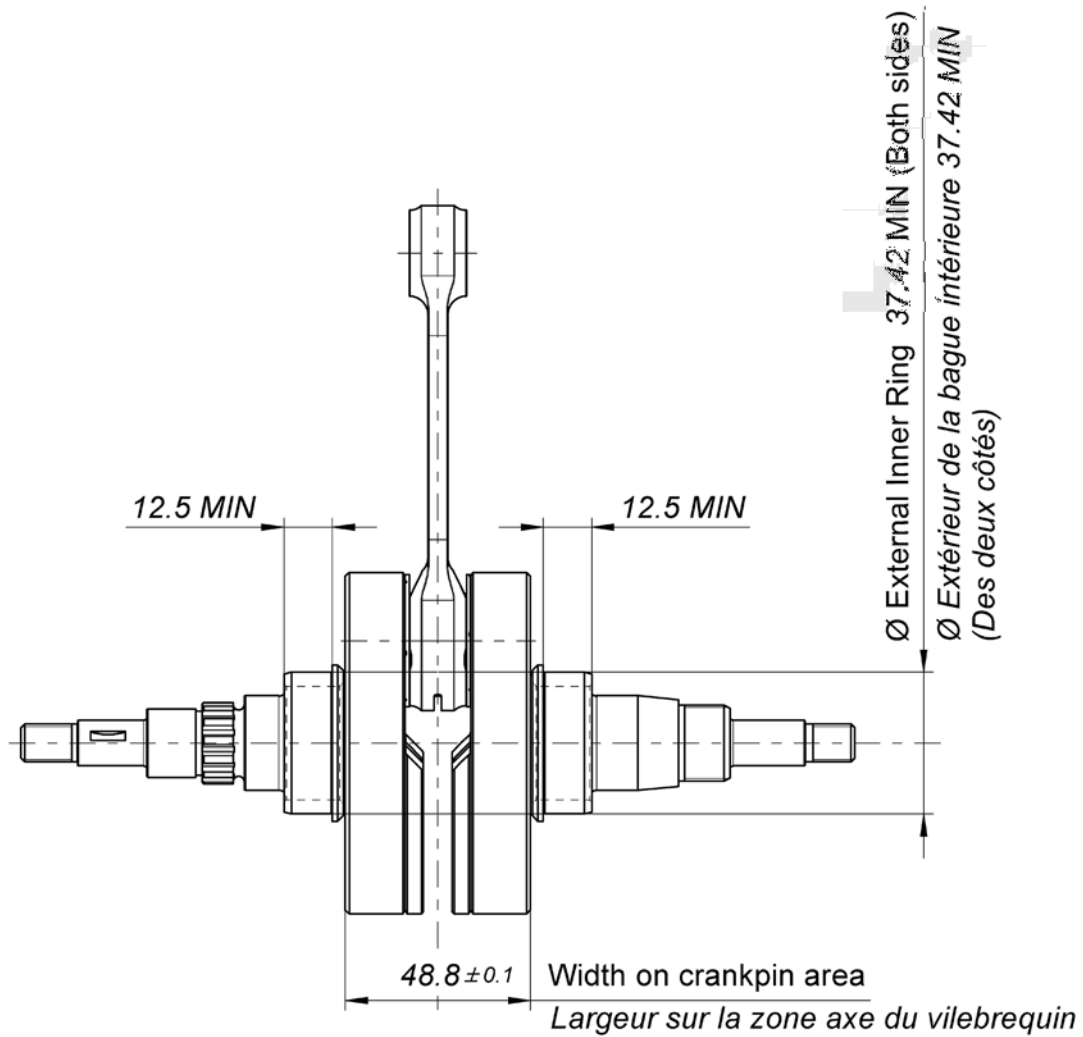

Crankshaft complete min. Weight 2220 g  
 Poids min. du vilebrequin

ROLLER MAIN BEARING  
 ROULEMENTS À ROULEAUX DU VILEBREQUIN

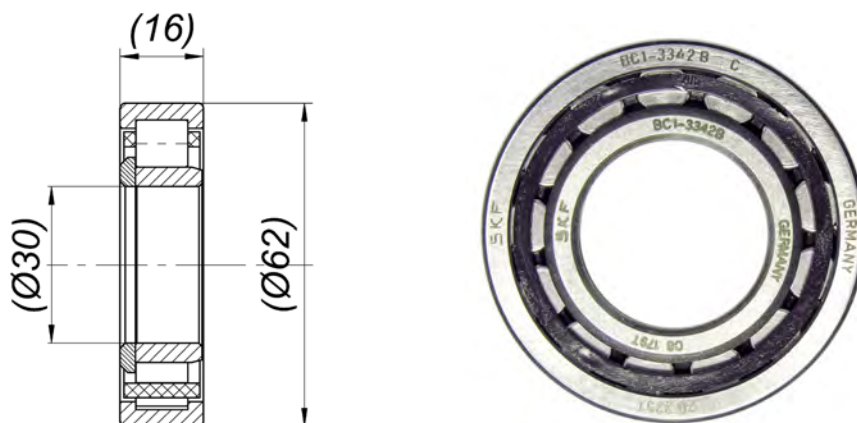

# CYLINDER DEVELOPMENT - DEVELOPPEMENT DU CYLINDRE

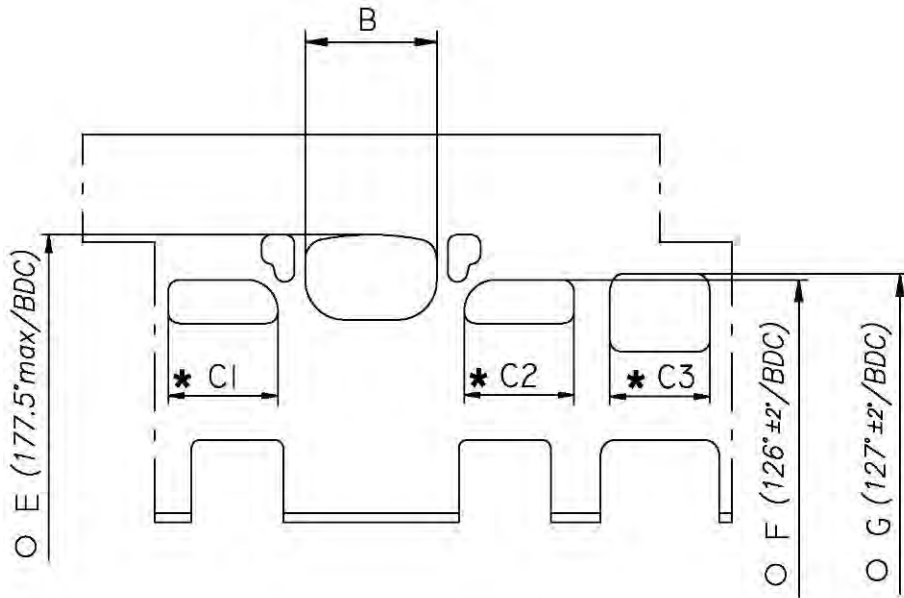

B	≤ 36.5 mm
C1 = C2	≤ 30 mm
C3	≤ 28.5 mm
E	177.5° max
F	126° ± 2°
G	127° ± 2°

\* **CHORDAL READING**  
LECTURE CORDALE

O **ANGULAR READING BY INSERTING A 0.2x5 mm GAUGE**  
LECTURE ANGULAIRE PAR INSERTION D'UNE CALE DE 0.2x5 mm

## CYLINDER BASE VIEW VUE DE LA BASE DU CYLINDRE

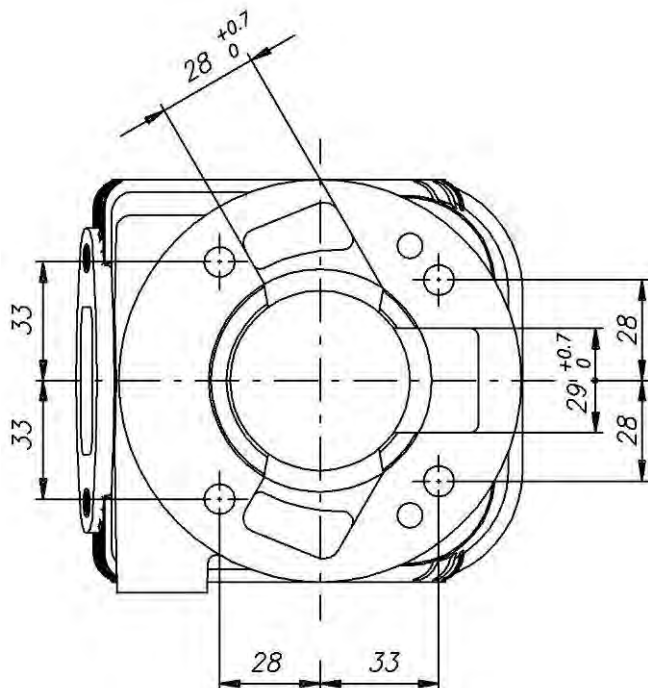

## CYLINDER CROSS SECTION VIEW VUE EN SECTION DU CYLINDRE

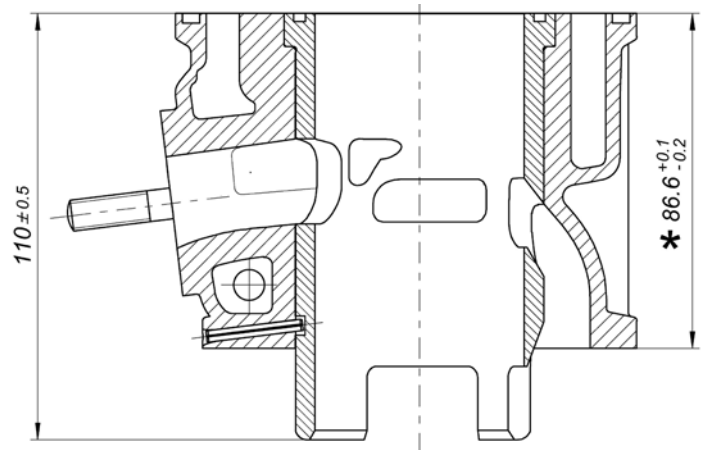

\* from the base plane of the cylinder  
to the top plane of the liner  
à partir du plan de base du cylindre  
jusqu'au plan supérieur de la chemise

COMBUSTION CHAMBER VIEW  
VUE DE LA CHAMBRE DE COMBUSTION

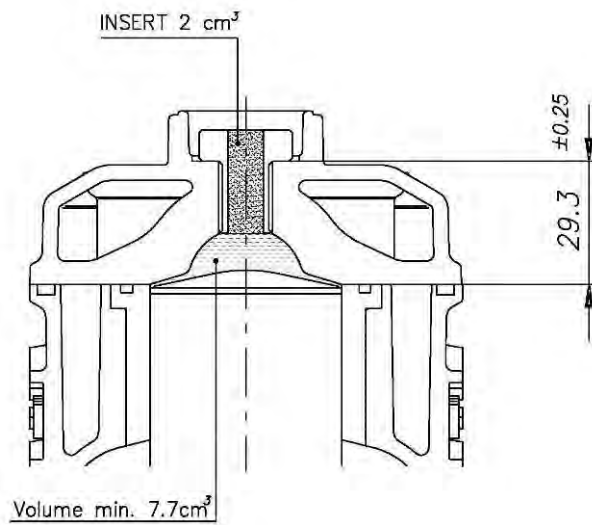

COMBUSTION CHAMBER VOLUME TOT. = 9.7 cm<sup>3</sup> min.  
VOLUME CHAMBRE COMBUSTION TOT. = 9.7 cm<sup>3</sup> min.

**ATT. : SQUISH MIN. = 0.90 mm**  
(measured with Ø1.5mm TIN - mesurée avec de l'étain Ø1.5mm)

CRANKCASE INSIDE VIEW  
VUE A' L' INTERIEUR DU CARTER

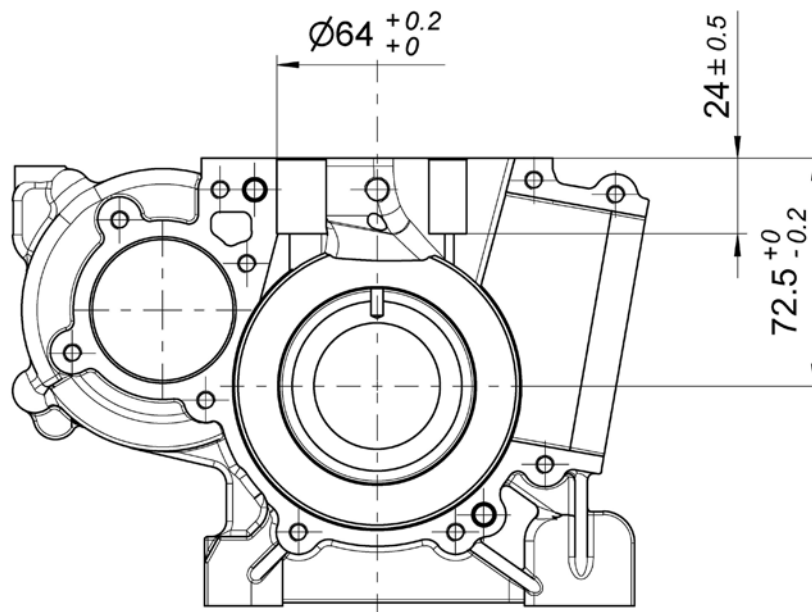

TILLOTSON HW-27A VENTURI CARBURETTOR DIMENSIONS  
 DIMENSIONS DU VENTURI DU CARBURATEUR TILLOTSON HW-27A

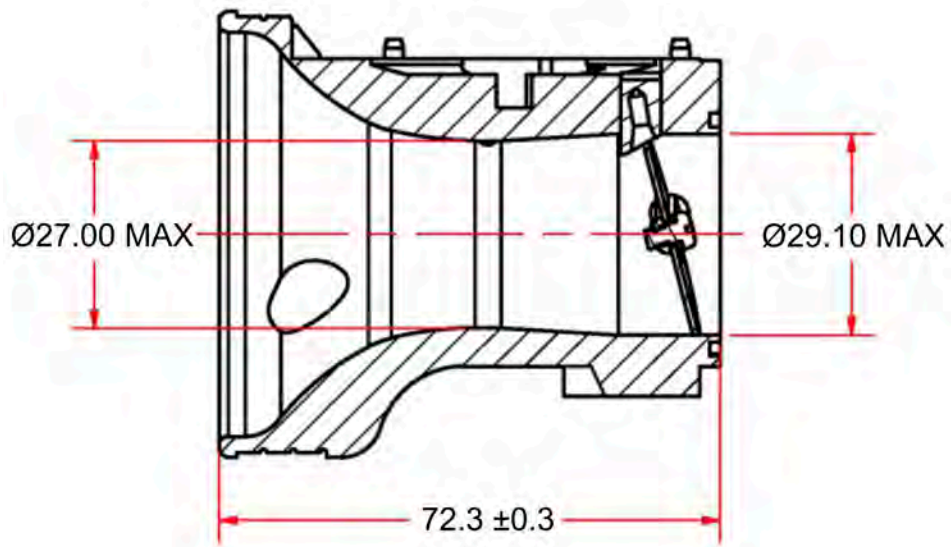

INLET CONVEYOR DIMENSIONS  
 CONVOYEUR D'ADMISSION

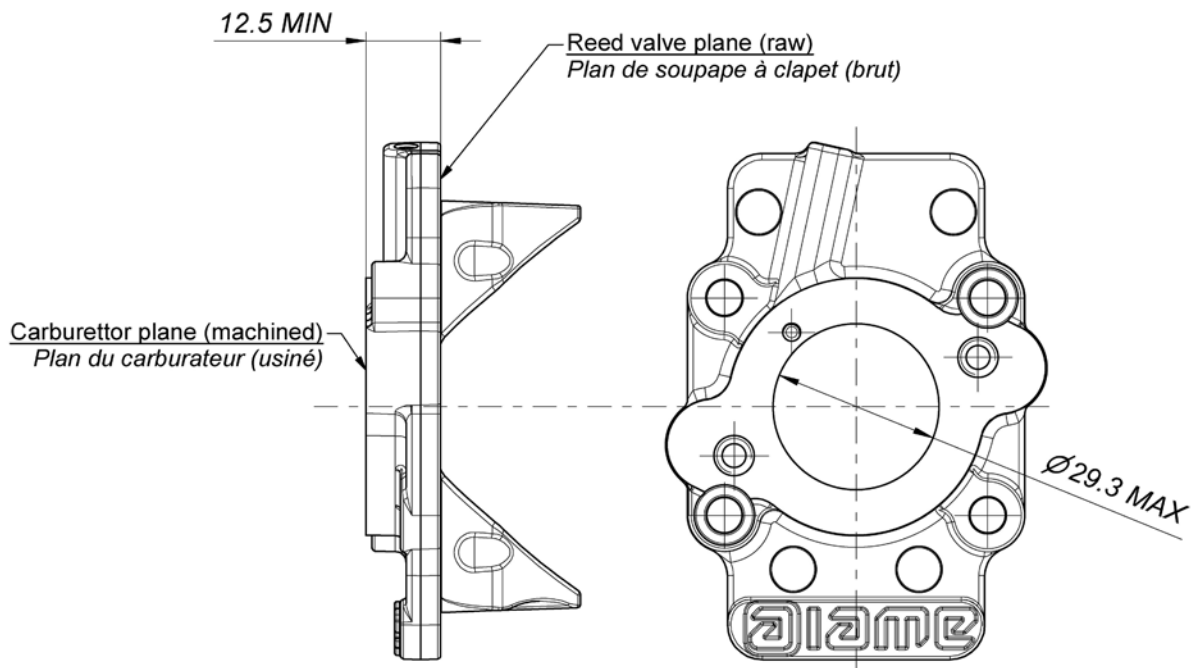

REED VALVE - DIMENSIONS AND MARKING  
BOÎTE À CLAPETS - DIMENSIONS ET MARQUAGE

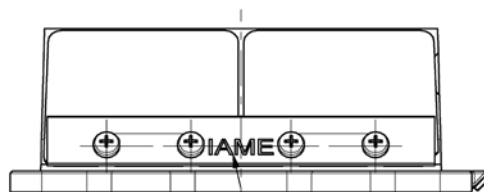
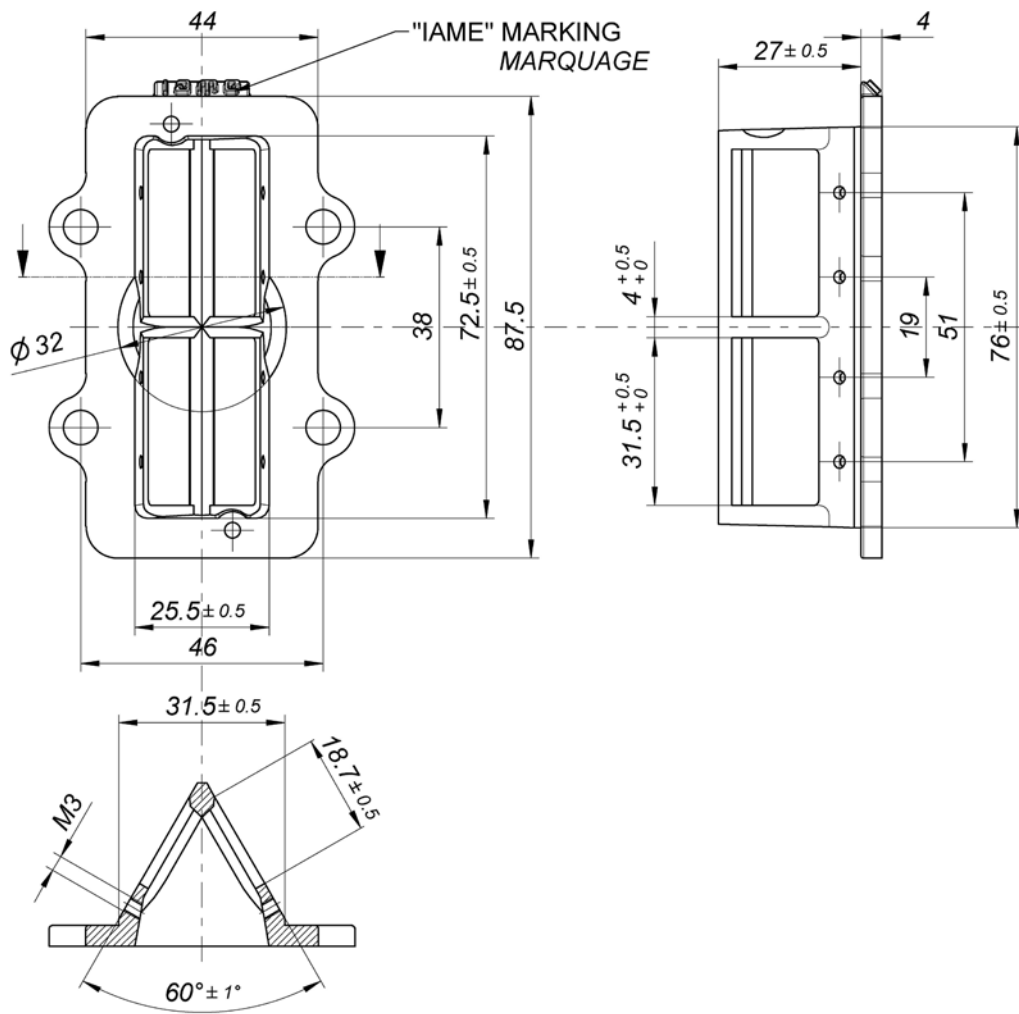

"IAME"  
MARKING / MARQUAGE

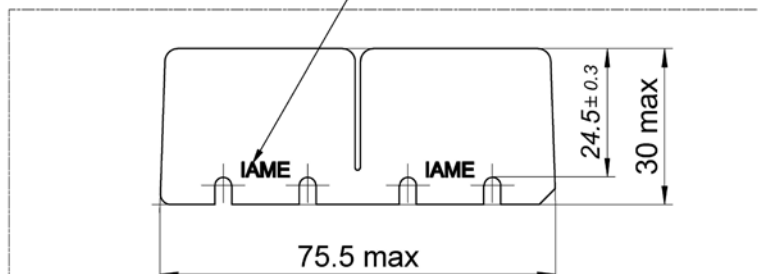

Genuine IAME vetronite reeds min. thickness 0.30mm  
*Clapets IAME authentique en fibre de verre 0.30mm épaisseur mini*

Genuine IAME carbon fiber reeds min. thickness 0.24mm  
*Clapets IAME authentique en fibre de carbone 0.24mm épaisseur mini*

INLET SILENCER – DRAWING  
DESSIN DU SILENCIEUX D'ADMISSION

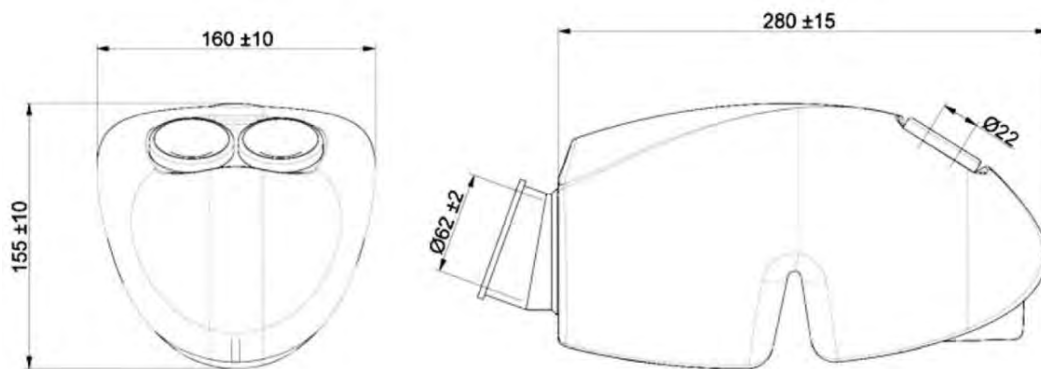

WITH SPONGE AIR FILTER  
AVEC MANCHON COMPLET ET FILTRE À AIR

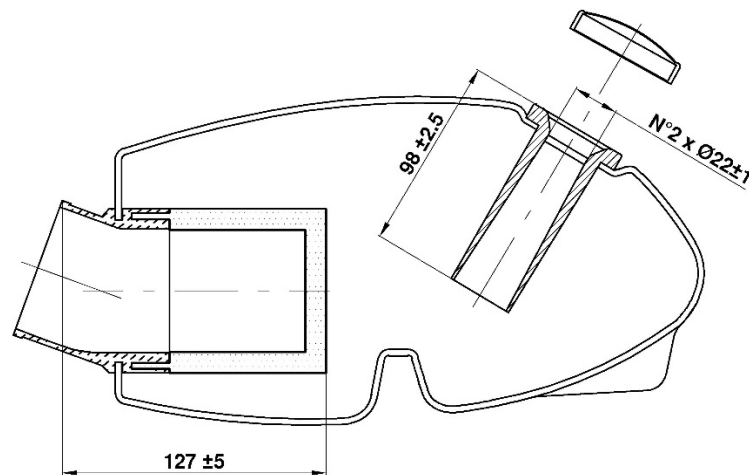

INLET SILENCER - PHOTO  
PHOTO - SILENCIEUX D'ADMISSION





RAIN COVER INLET SILENCER – DRAWING  
DESSIN DU COUVERTURE POUR LA PLUIE DU SILENCIEUX D'ADMISSION

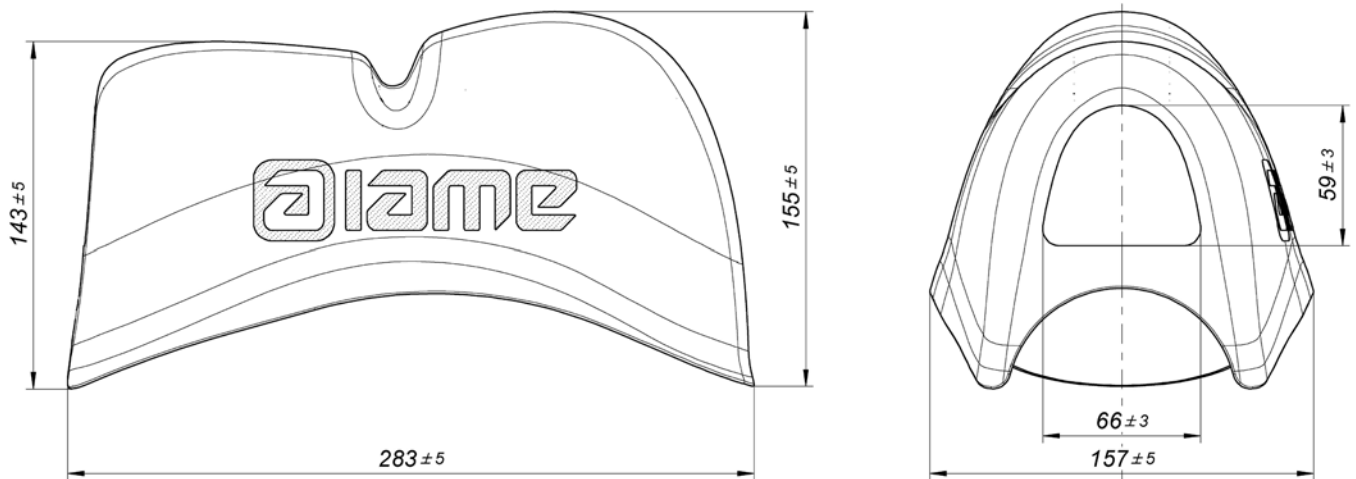

RAIN COVER INLET SILENCER - PHOTO  
PHOTO - COUVERTURE POUR LA PLUIE DU SILENCIEUX D'ADMISSION



DESCRIPTION OF THE CLUTCH - DESCRIPTION DE L'EMBRAYAGE

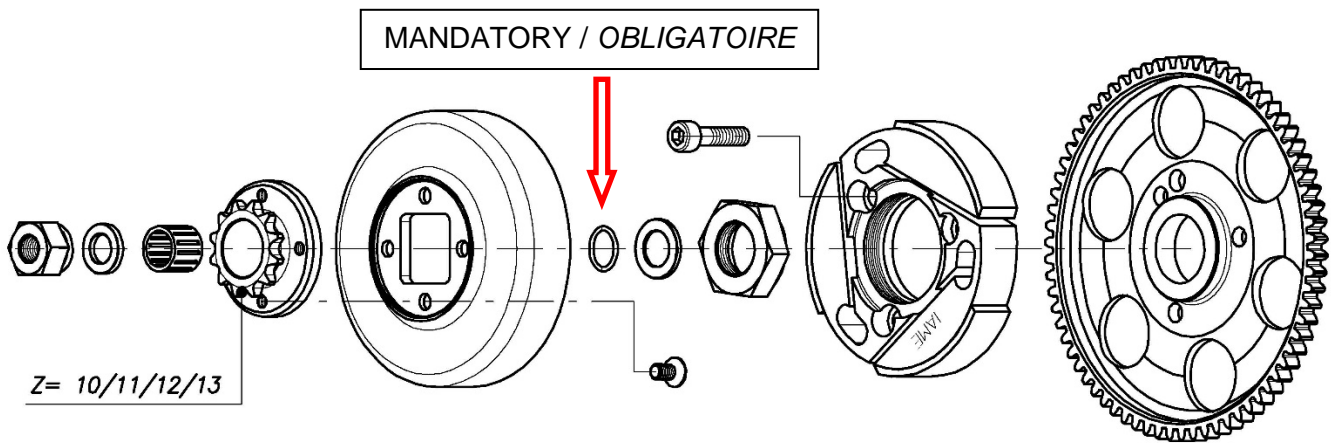

COMPONENTS OF THE CLUTCH – COMPOSANTS DE L'EMBRAYAGE

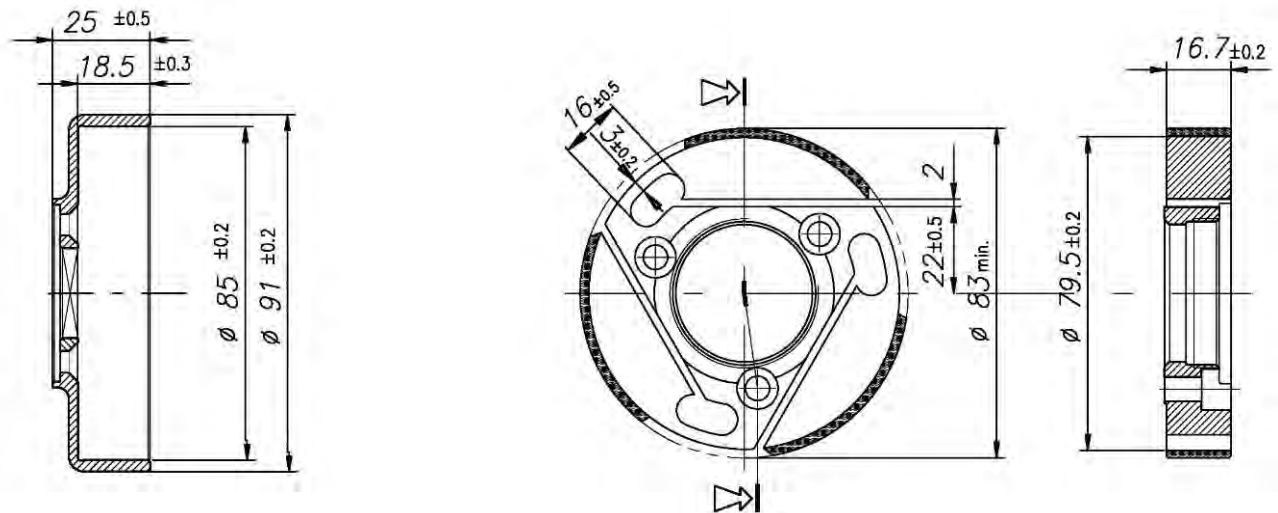

Min. weight 225 g  
Poids min. 225g

Min. weight 375 g  
Poids min. 375g

EXHAUST MUFFLER VIEW AND DIMENSIONS  
VUE ET DIMENSIONS DU SILENCIEUX D'ÉCHAPPEMENT

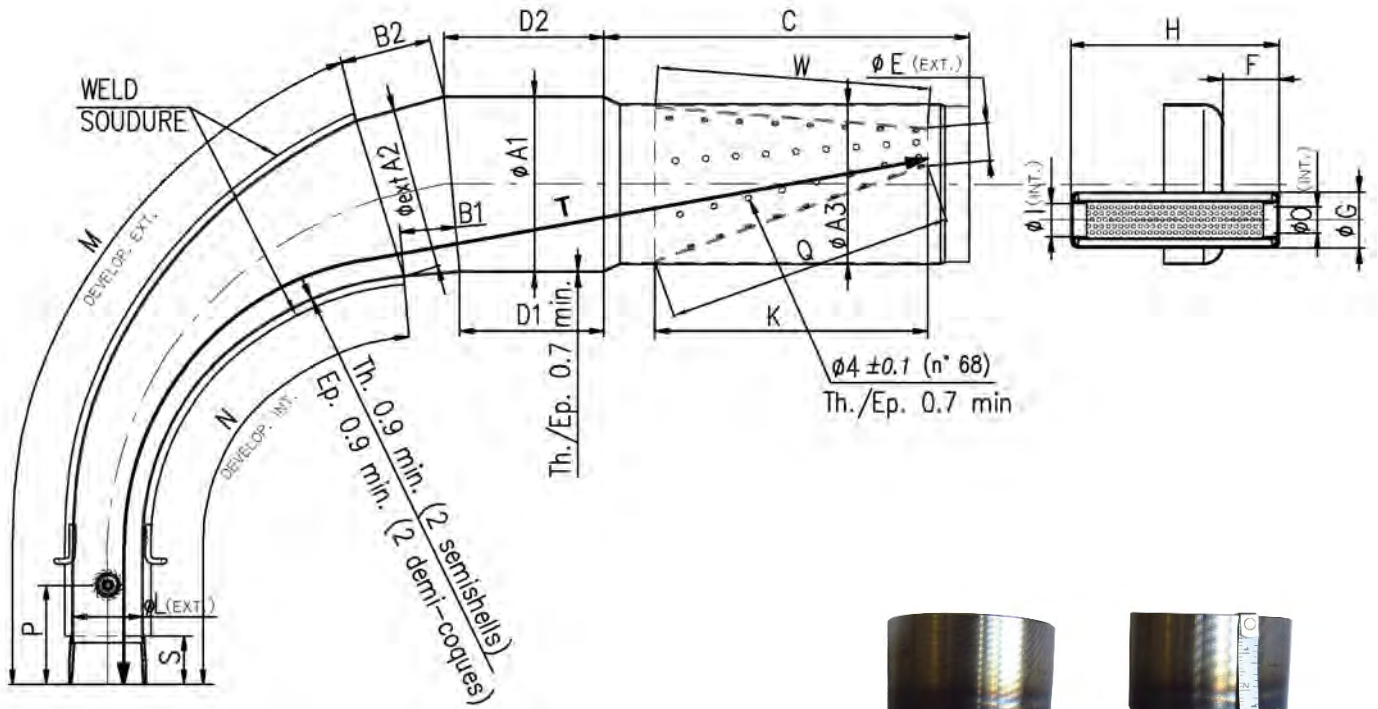

The tape must follow the centerline of the weld at all points.

Le ruban doit suivre l'axe de la soudure en tous points.

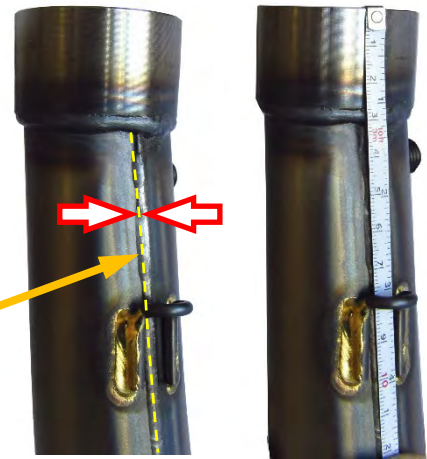

Min. Weight 1.780 g  
Poids min. 1.780 g

<b>ØA1:</b> 110 ±1.5 Øext.	<b>B2:</b> 60 ±3	<b>ØE:</b> 23.5 ±2 Øext.	<b>ØI:</b> 21 ±1 Øint.	<b>N:</b> 341 ±3	<b>T:</b> 690 ±3
<b>ØA2:</b> 102 ±1.5 Øext.	<b>C:</b> 219 ±3	<b>F:</b> 36 ±2	<b>K:</b> 170 ±3	<b>ØO:</b> 21 ±1 Øint.	<b>W:</b> 170 ±3
<b>ØA3:</b> 100 ±1.5 Øext.	<b>D1:</b> 90 ±3	<b>ØG:</b> 35 ±1 Øext.	<b>ØL:</b> 42.5 ±1.5 Øext.	<b>P:</b> 50 ±10	<b>Q:</b> 182 ±3
<b>B1:</b> 60 ±3	<b>D2:</b> 109 ±3	<b>H:</b> 132 ±3	<b>M:</b> 439 ±3	<b>S:</b> 29 ±1.5	

**ATTENTION:**

The dimensions "M", "N" and "T" must be taken by steel tape measure 6mm wide.  
The dimensions "M" and "N" must be taken on the weld centerline.

Les dimensions « M », « N » et « T » doivent être prises à l'aide d'un ruban à mesurer en acier 6 mm de large.

Les dimensions « M », « N » doivent être prises sur l'axe de la soudure.

The dimensions "Q" and "W" must be taken by steel tape measure 12mm wide.

Les dimensions « Q » et « W » doivent être prises à l'aide d'un ruban à mesurer en acier 12 mm de large.

SENIOR EXHAUST FITTING  
RACCORD D'ÉCHAPPEMENT SENIOR

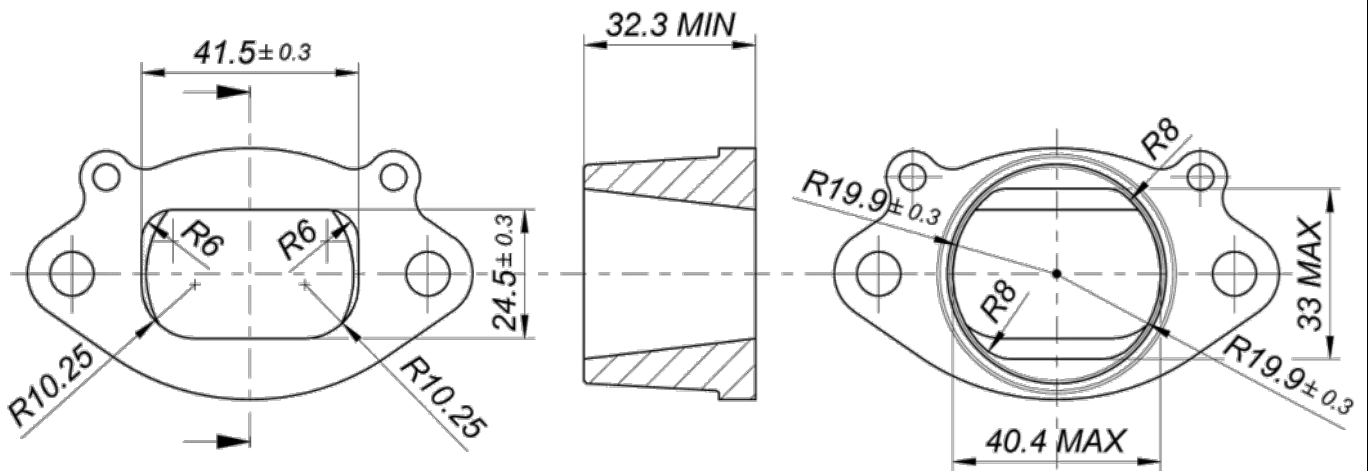

SENIOR EXHAUST INSTALLATION  
INSTALLATION DE L'ÉCHAPPEMENT SENIOR

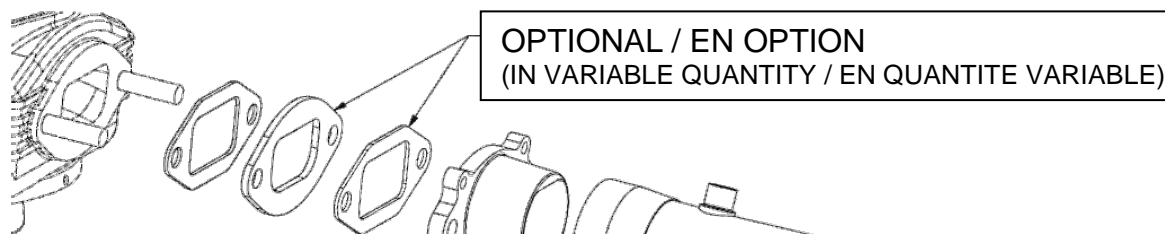

**OPTIONAL / EN OPTION**  
**Part n° cod. X30125375**

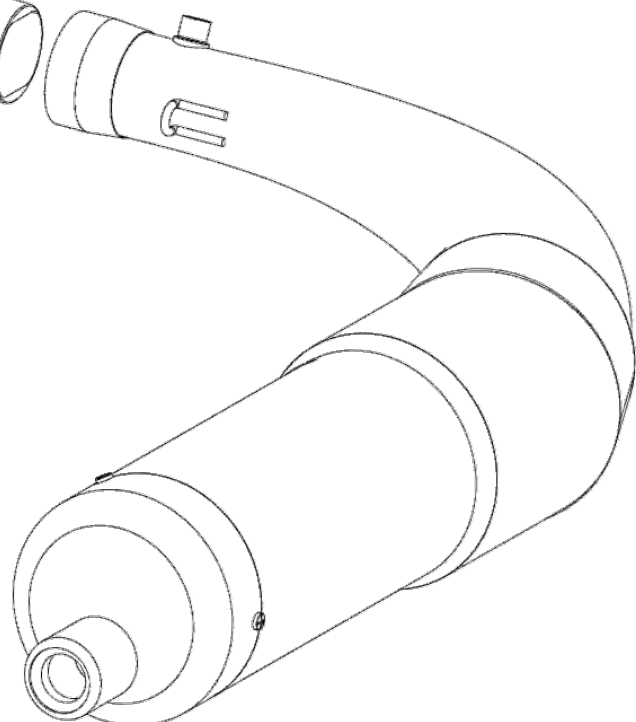
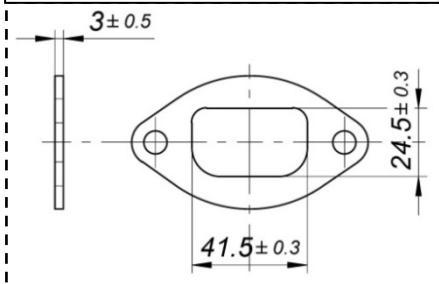

JUNIOR EXHAUST FITTING  
RACCORD D'ÉCHAPPEMENT JUNIOR

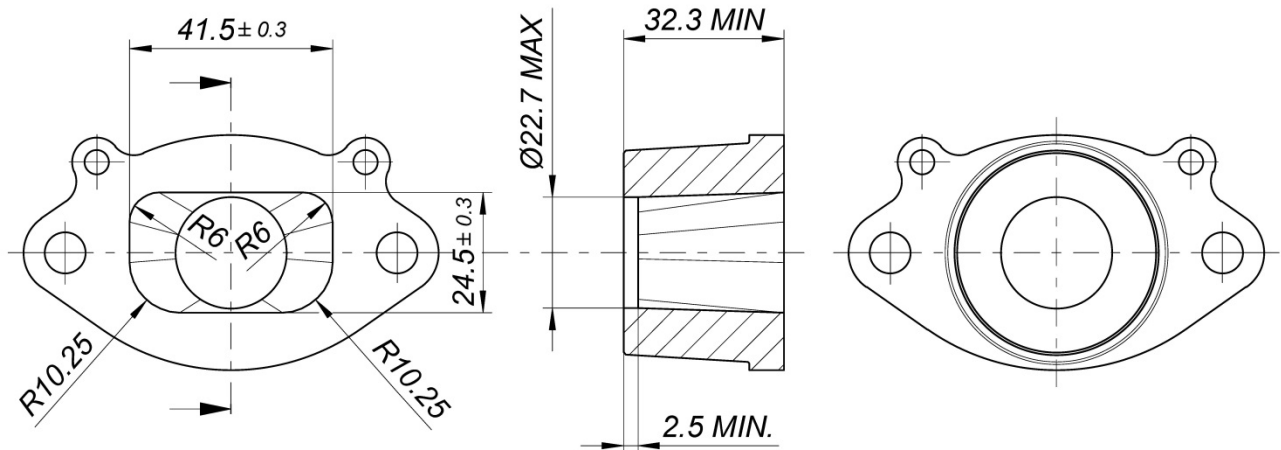

JUNIOR EXHAUST INSTALLATION  
INSTALLATION DE L'ÉCHAPPEMENT JUNIOR

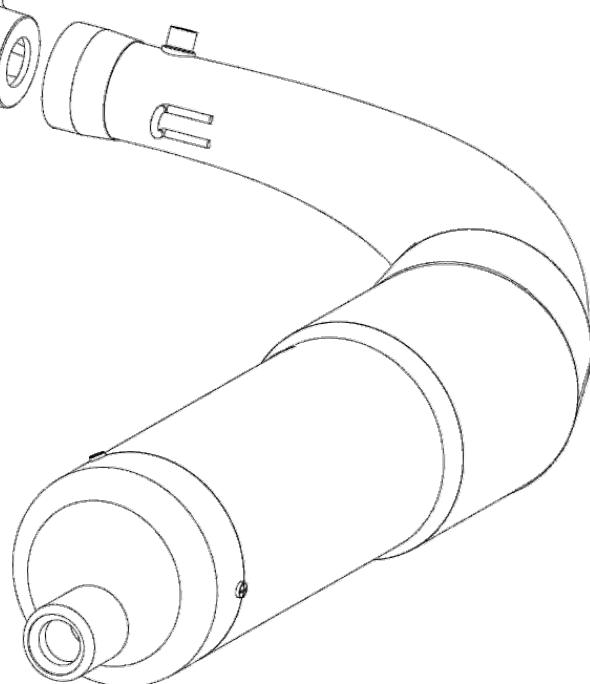
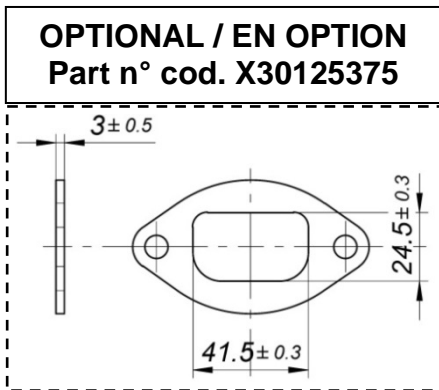
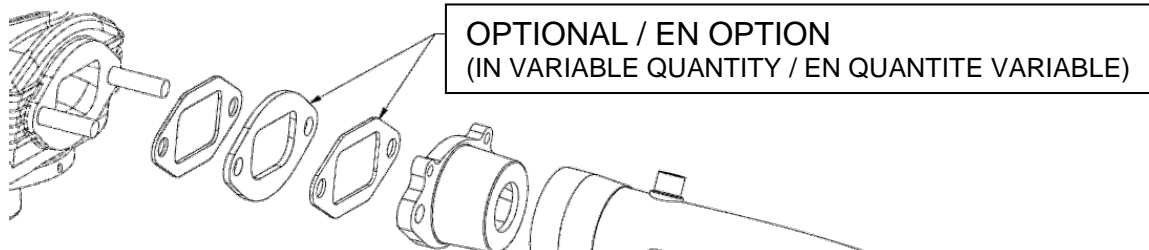

WIRING DIAGRAM ( SELETTRA DIGITAL "K" IGNITION )  
 SCHEMA CIRCUIT ELECTRIQUE ( ALLUMAGE SELETTRA DIGITAL "K" )

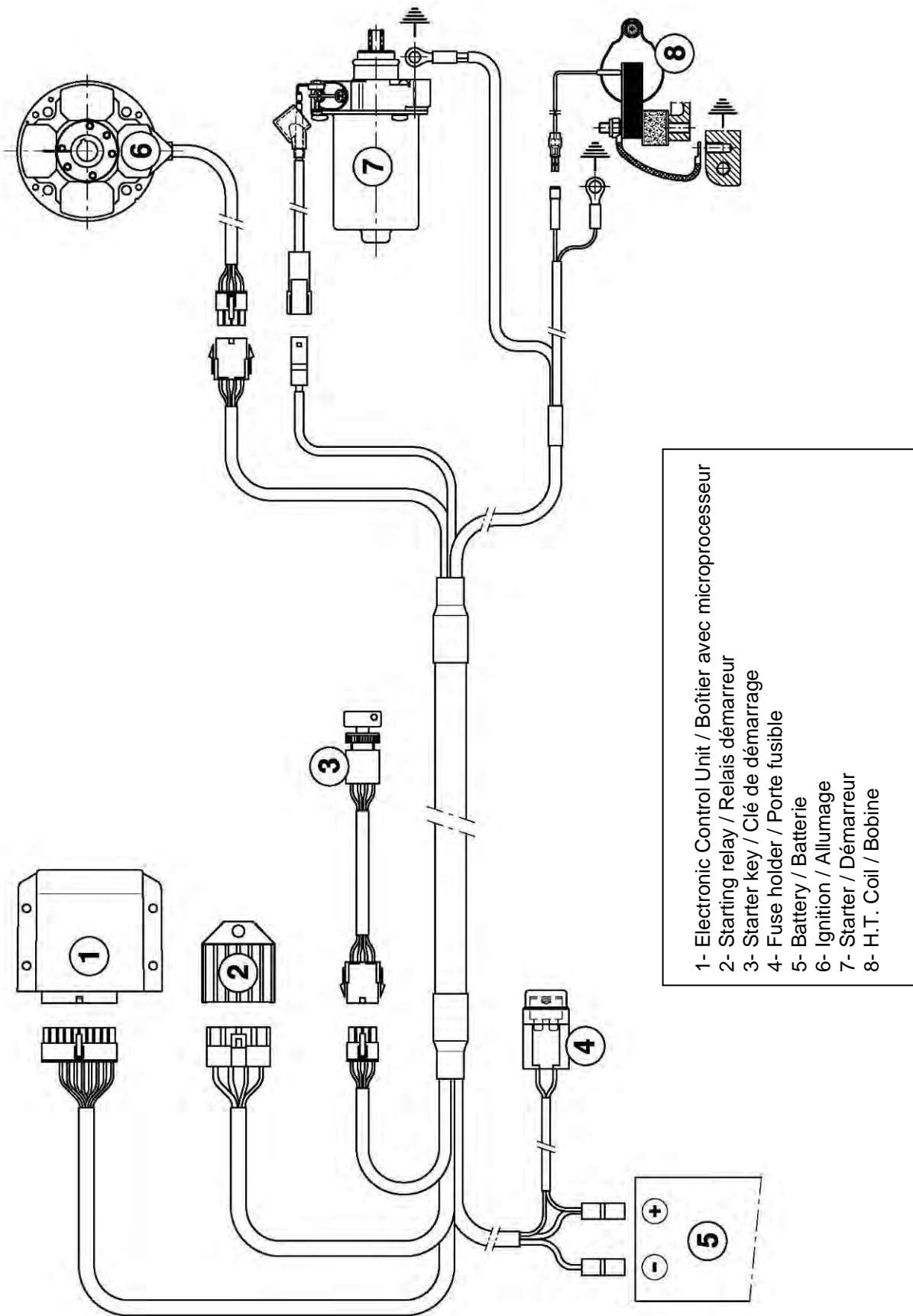

- 1- Electronic Control Unit / Boîtier avec microprocesseur
- 2- Starting relay / Relais démarrage
- 3- Starter key / Clé de démarrage
- 4- Fuse holder / Porte fusible
- 5- Battery / Batterie
- 6- Ignition / Allumage
- 7- Starter / Démarreur
- 8- H.T. Coil / Bobine

**SCHEME FOR ADVANCE CONTROL  
SCHEMA POUR LE CONTROLE DE L'AVANCE**

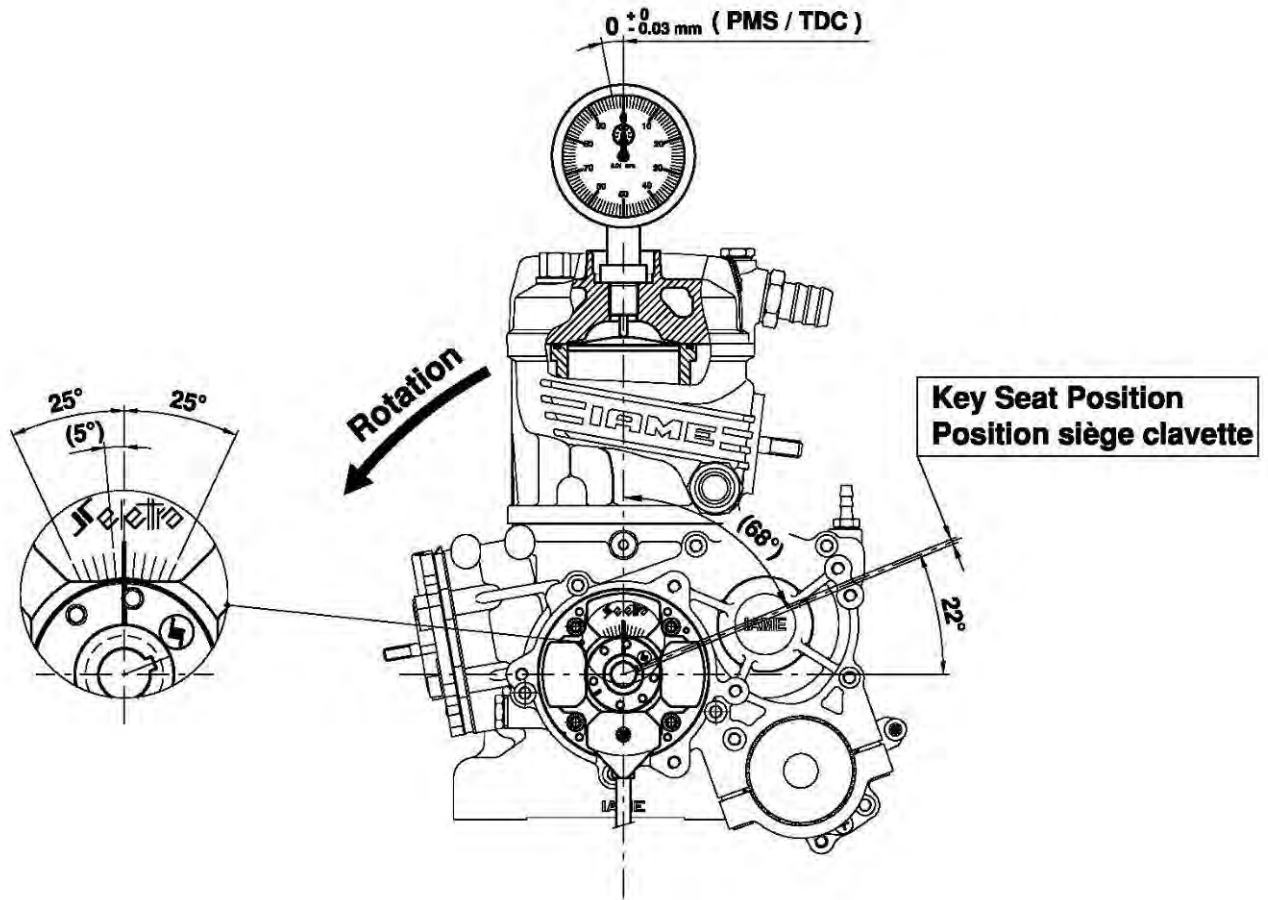

**ADVANCE CURVE GRAPHS / GRAPHIQUES DE LA COURBE D'AVANCE**

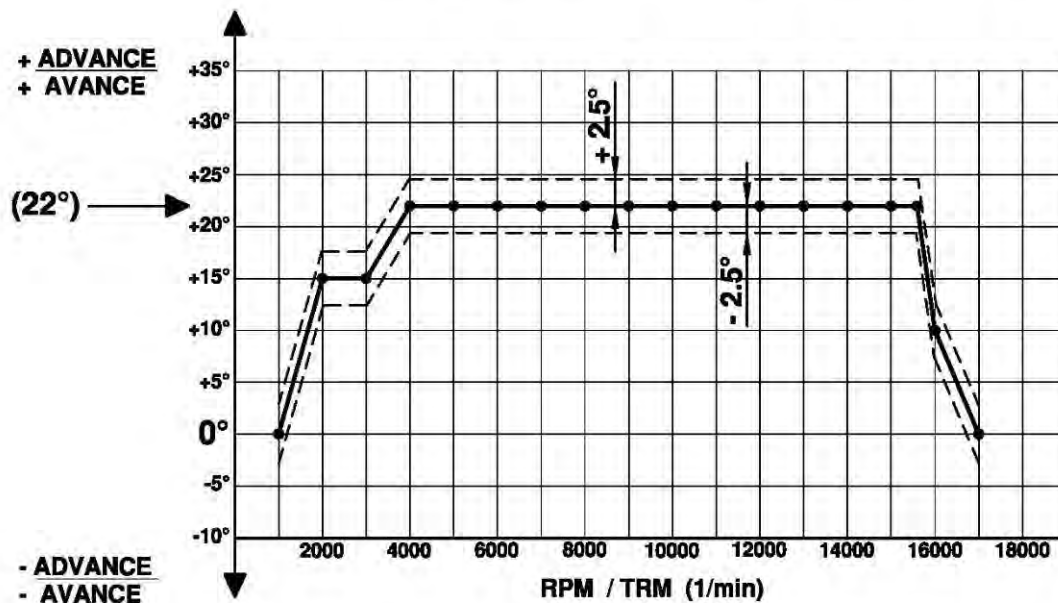

ELECTRONIC BOX MARKING  
MARQUAGE DU BOITIER ELECTRONIQUE

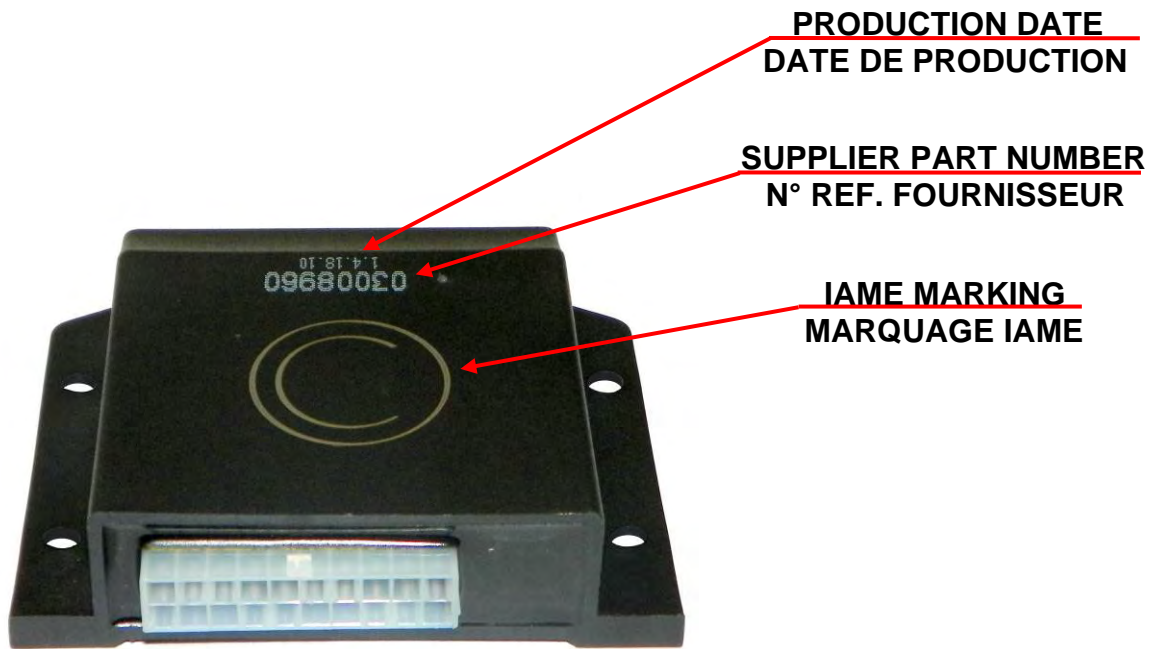

GEAR ALTERNATIVE FIXING  
FIXATION ALTERNATIVE DE L'ENGRENAGE

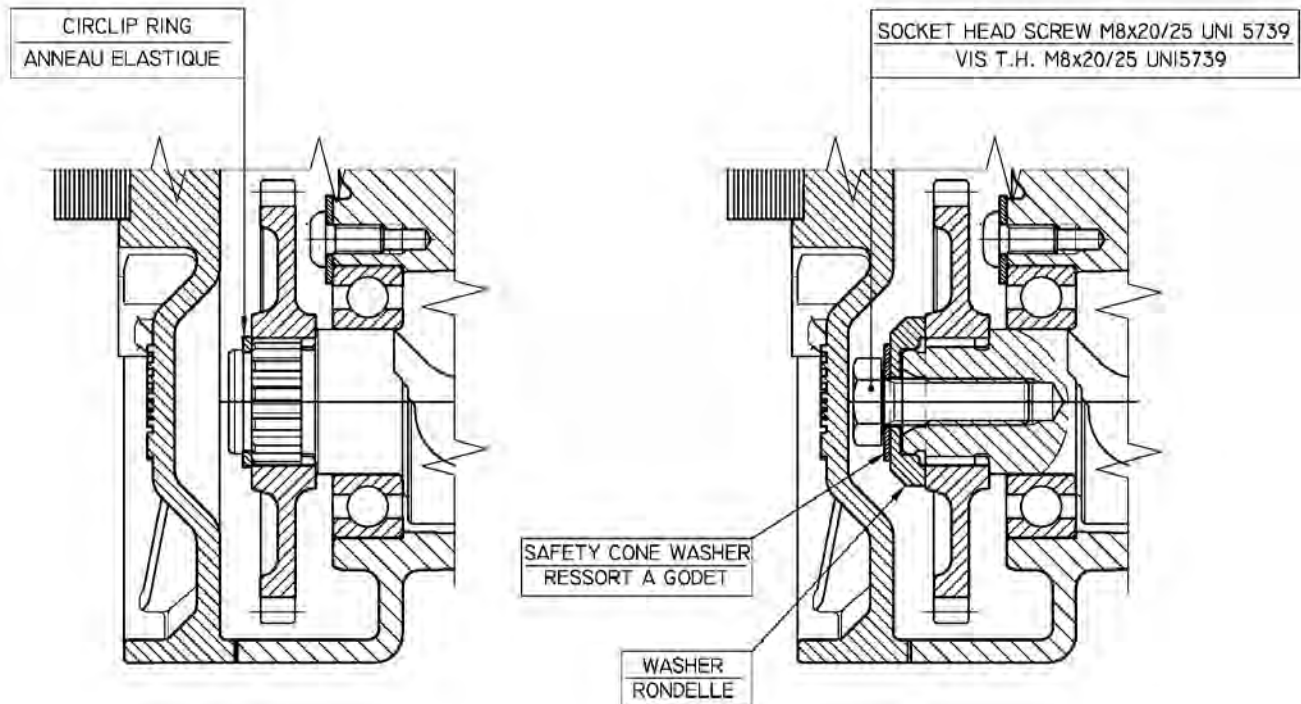



DESCRIPTION OF THE CLUTCH - *DESCRIPTION DE L' EMBRAYAGE*

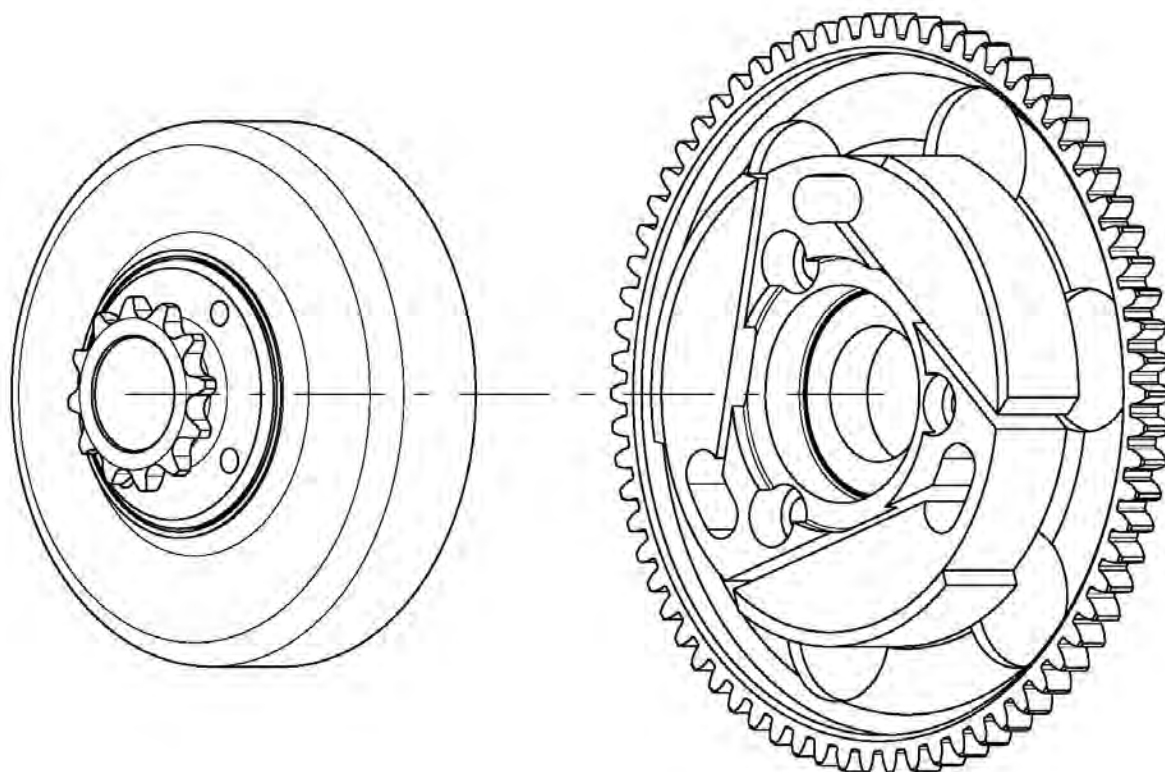

Min. weight 300 g  
*Poids min. 300 g*

Min. weight 680 g  
*Poids min. 680 g*

RADIATOR DESCRIPTION AND SKETCH OF PARTS  
 DESCRIPTION DU RADIATEUR ET SCHEMA ILLUSTRANT LES ELEMENTS

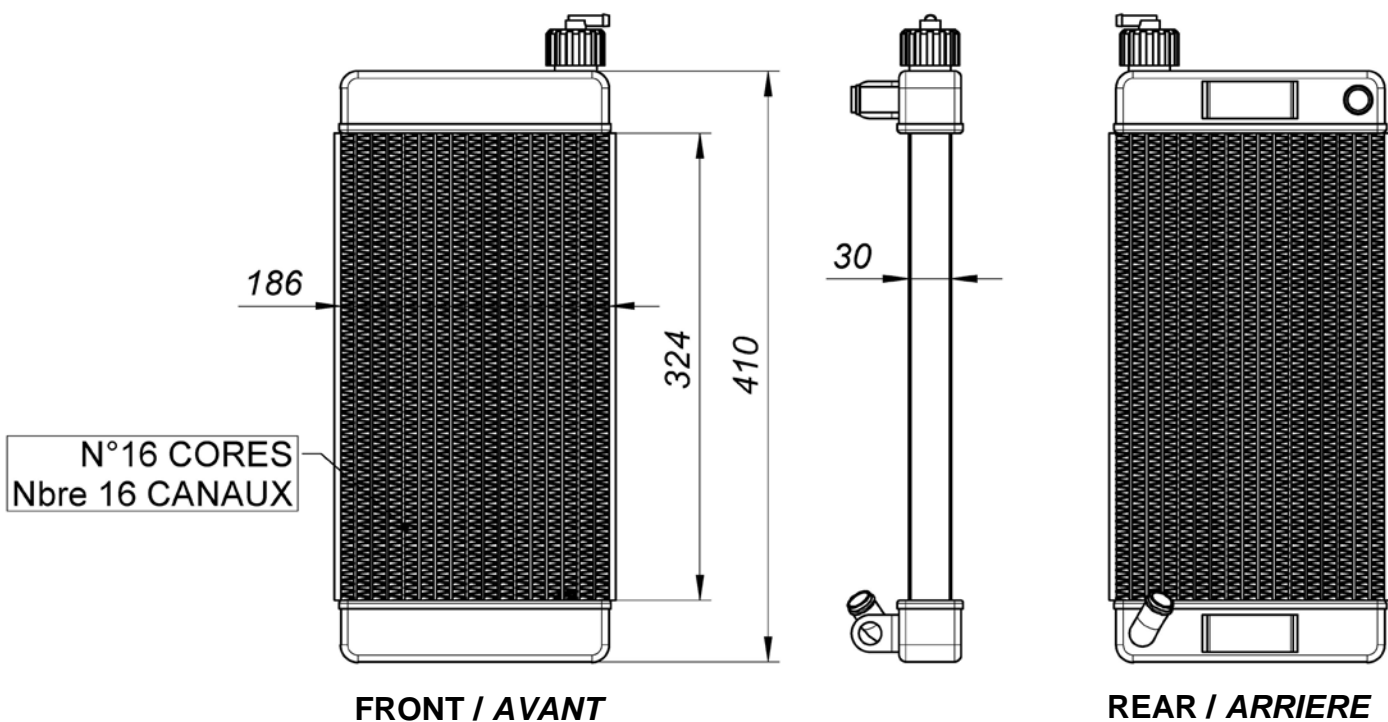

PAINTED AND NOT PAINTED  
PEINT ET PAS PEINT

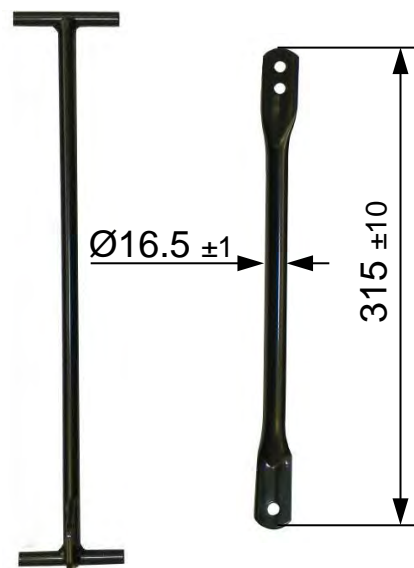

RADIATOR ALTERNATIVE DESCRIPTION AND SKETCH  
 DESCRIPTION DU RADIATEUR ALTERNATIF

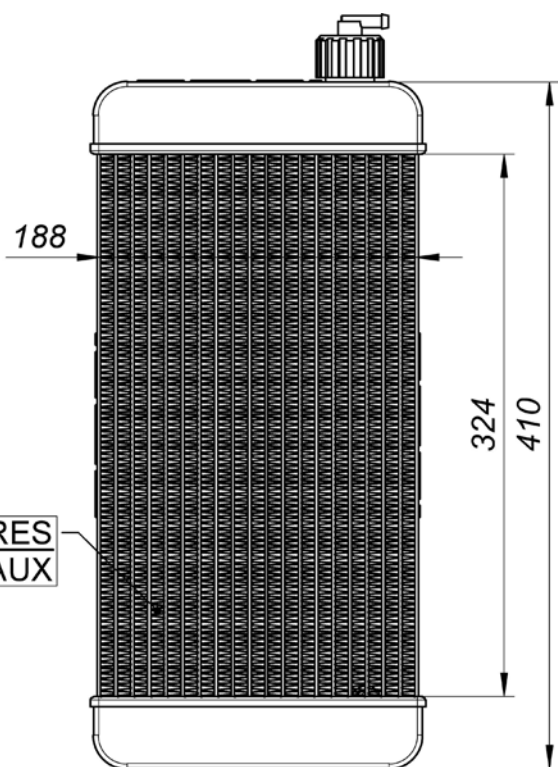

FRONT / AVANT

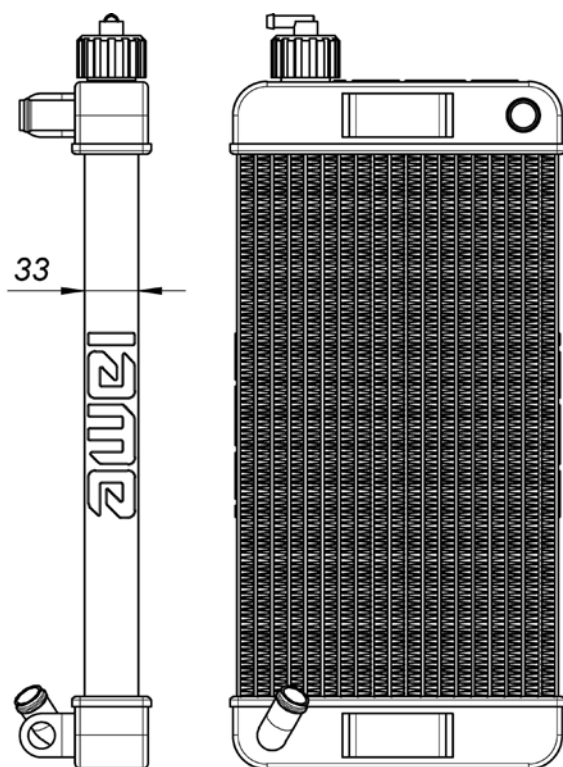

REAR / ARRIERE



FRONT / AVANT



REAR / ARRIERE

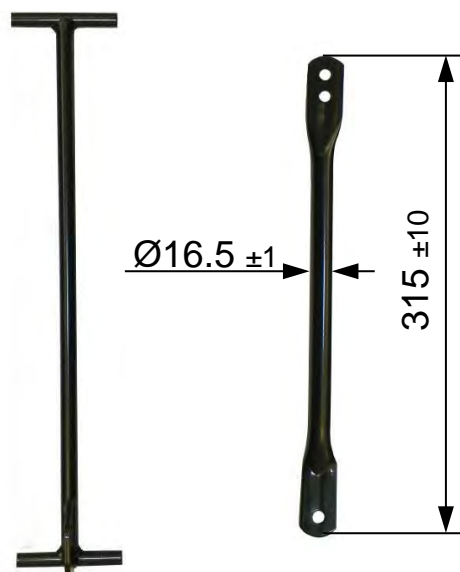

RADIATOR ALTERNATIVE DESCRIPTION AND SKETCH  
 DESCRIPTION DU RADIATEUR ALTERNATIF

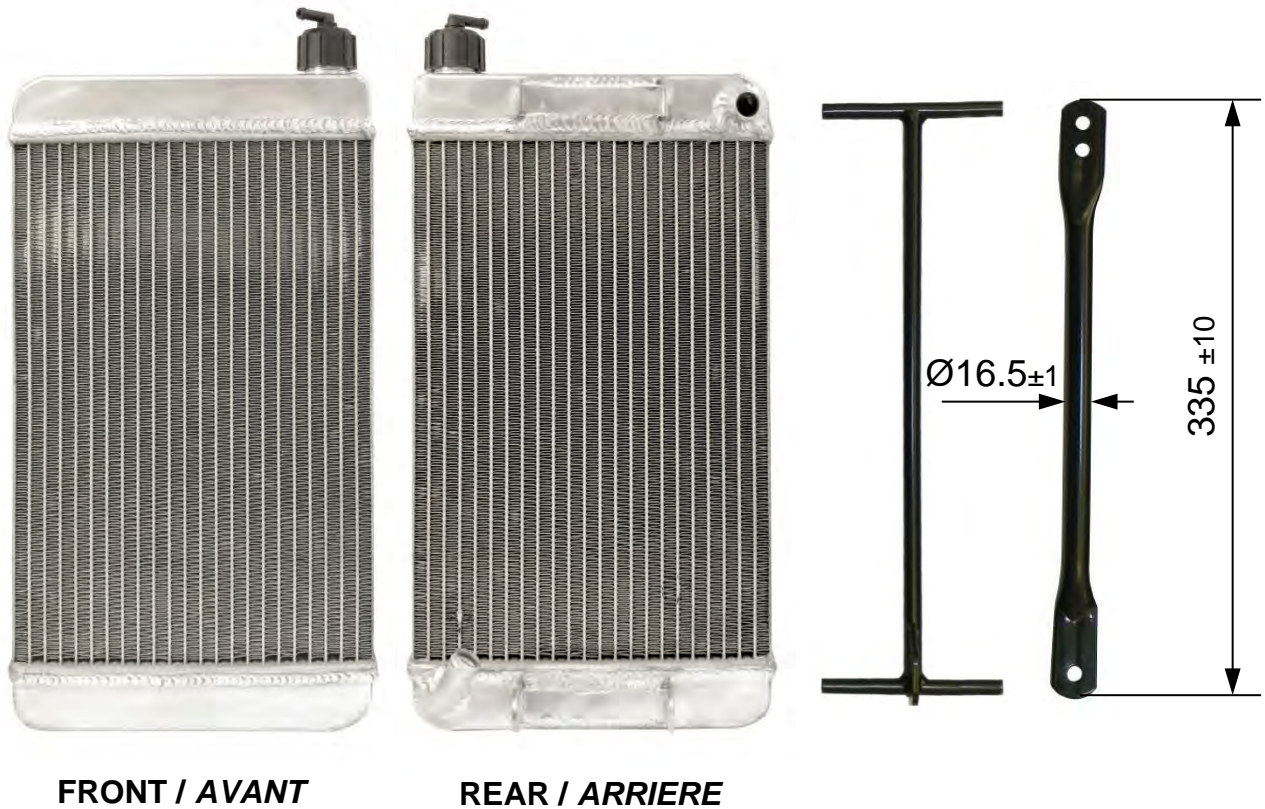
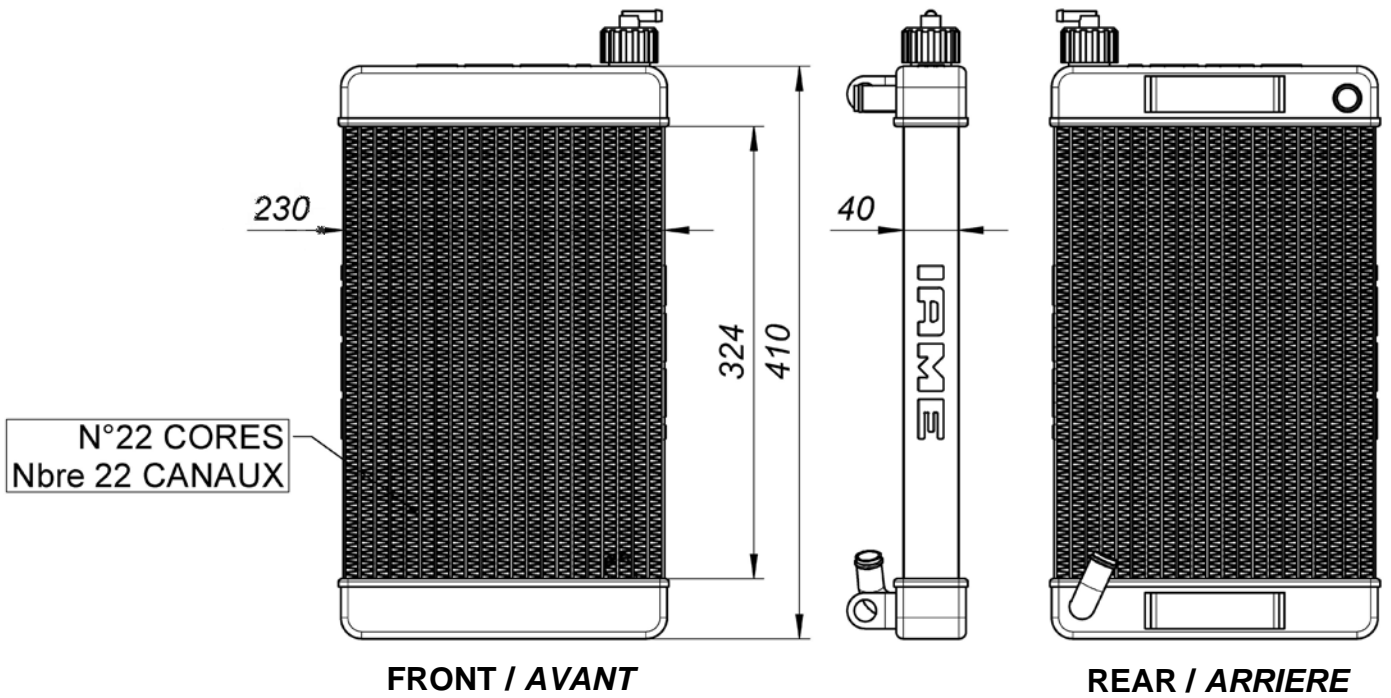

RADIATOR AND ITS SUPPORTS  
RADIATEUR ET SES SUPPORTS

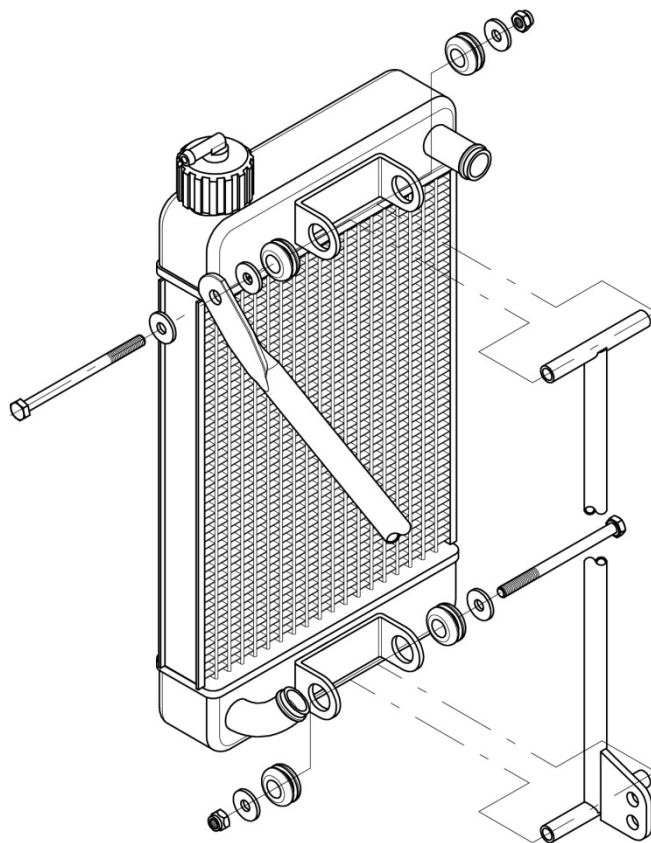

WATER PUMP GROUP  
GROUPE POMPE A' EAU

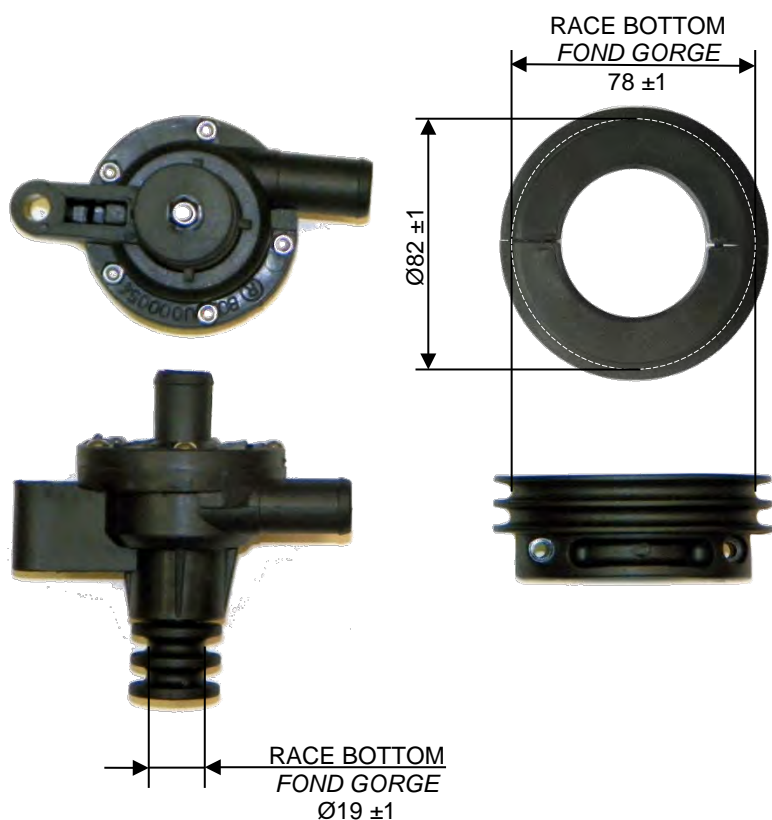

THERMOSTAT



ALTERNATIVE  
ALTERNATIF



ALTERNATIVE WATER PUMP & PULLEY  
 GROUPE POMPE A EAU ET POULIE ALTERNATIF

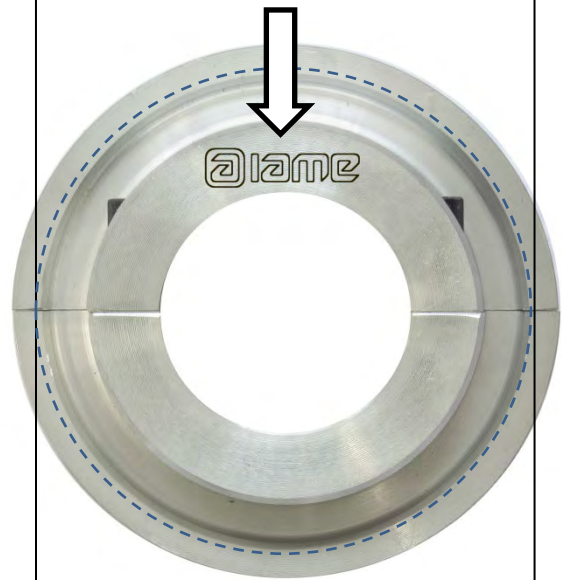
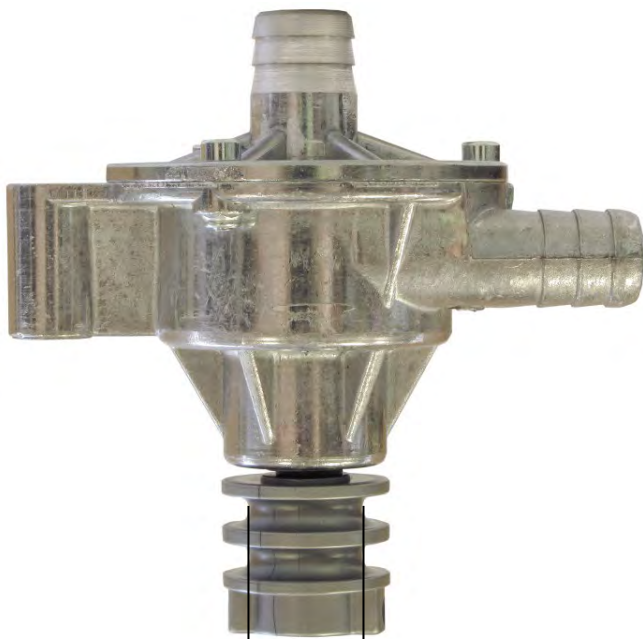

RACE BOTTOM - FOND GORGE  $\varnothing 82.5 \pm 1$

RACE BOTTOM - FOND GORGE  
 $\varnothing 20 \pm 1$

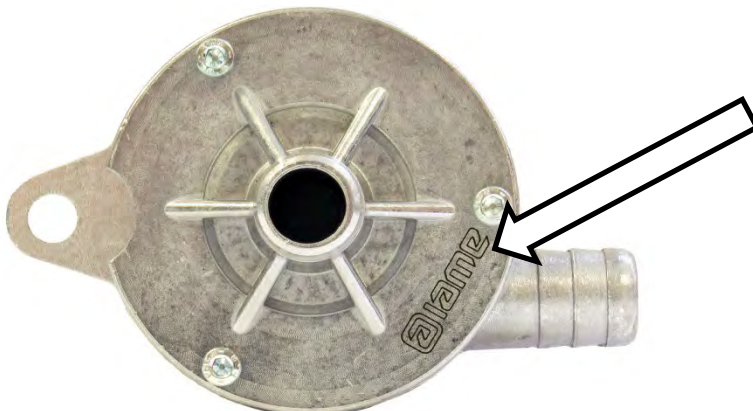

ALTERNATIVE RADIATOR SUPPORT  
SUPPORT ALTERNATIF DU RADIATEUR



PISTON IDENTIFICATION MARKING  
 MARQUAGE D'IDENTIFICATION PISTON

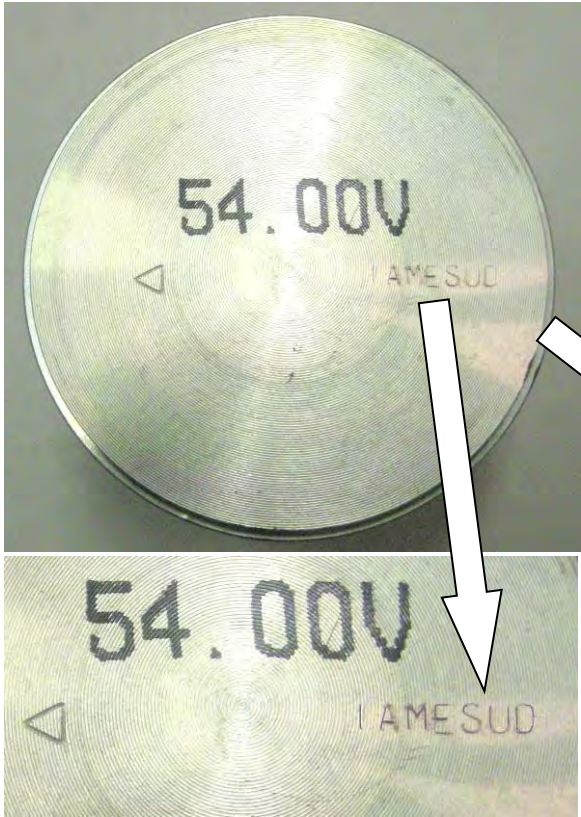
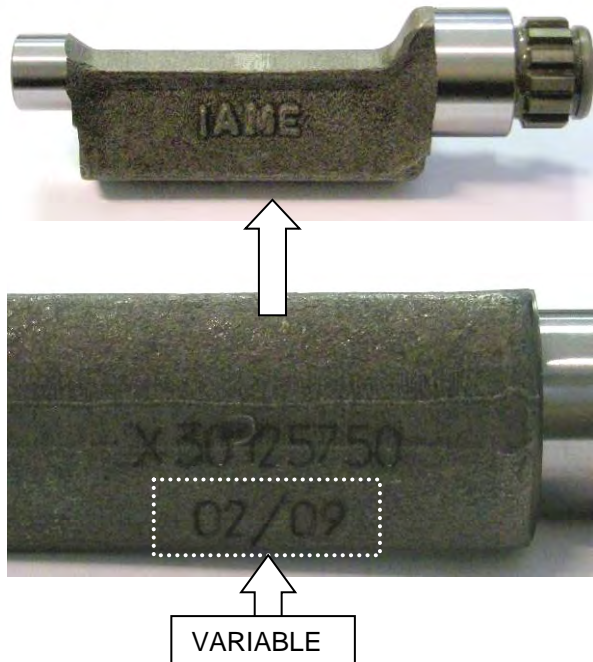
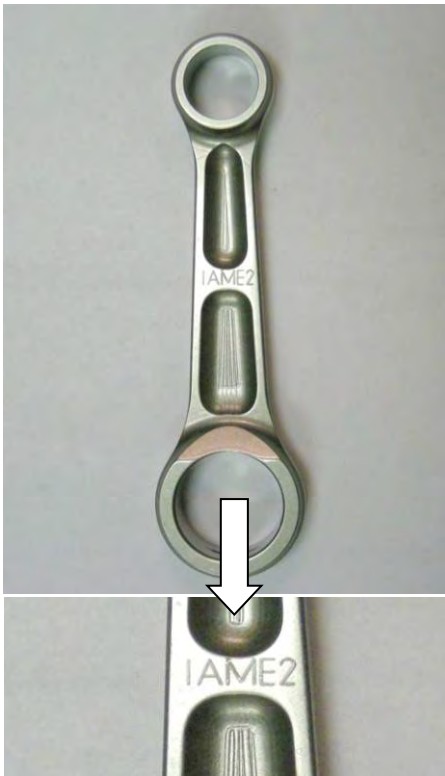

PHOTO IDENTIFICATION CONROD  
 PHOTO D'IDENTIFICATION BIELLE

IDENTIFICATION BALANCING SHAFT  
 MARKING  
 MARQUAGE D'IDENTIFICATION ARBRE  
 D'EQUILIBRAGE





CRANKSHAFT IDENTIFICATION MARKING  
MARQUAGE D'IDENTIFICATION DU VILEBREQUIN

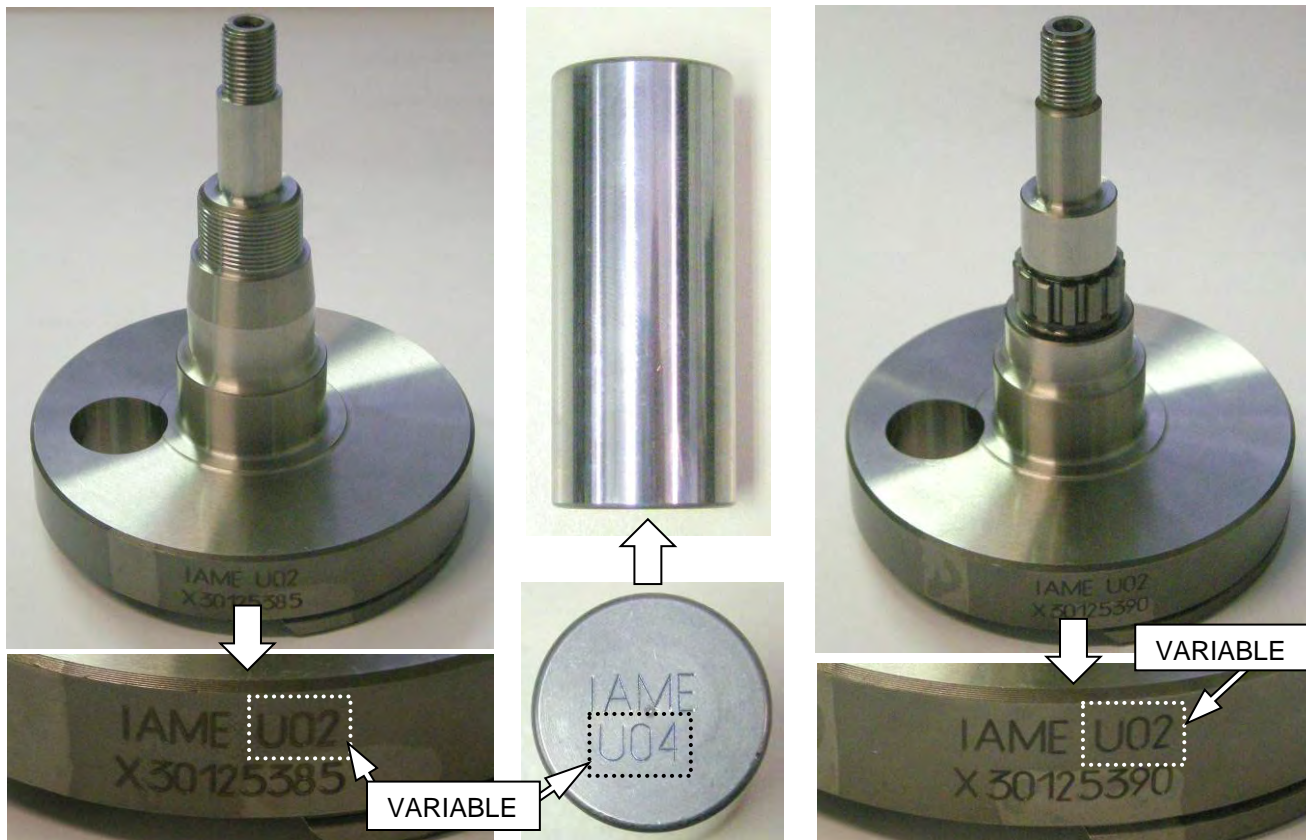

GEAR COMMAND BALANCING SHAFT  
IDENTIFICATION MARKING  
MARQUAGE D'IDENTIFICATION  
ENGRENAGE ARBRE D'EQUILIBRAGE

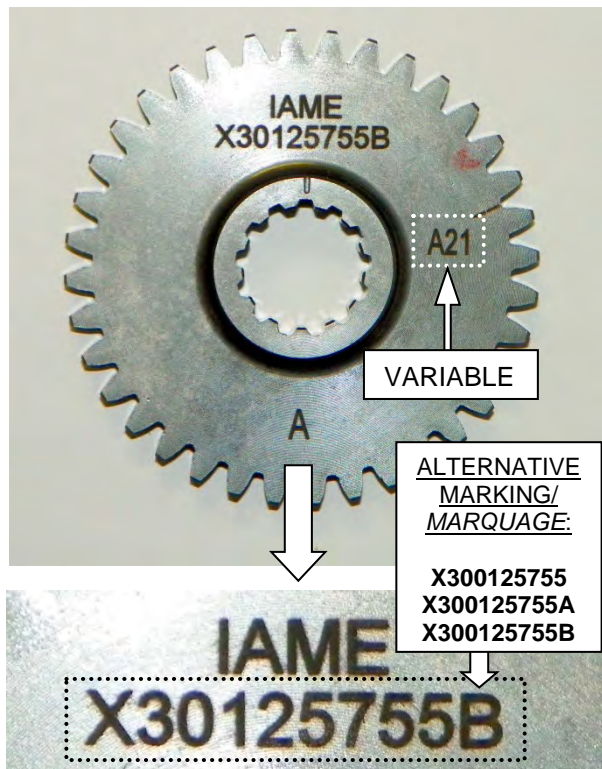

SPROCKET IDENTIFICATION MARKING  
MARQUAGE D'IDENTIFICATION DU PIGNON

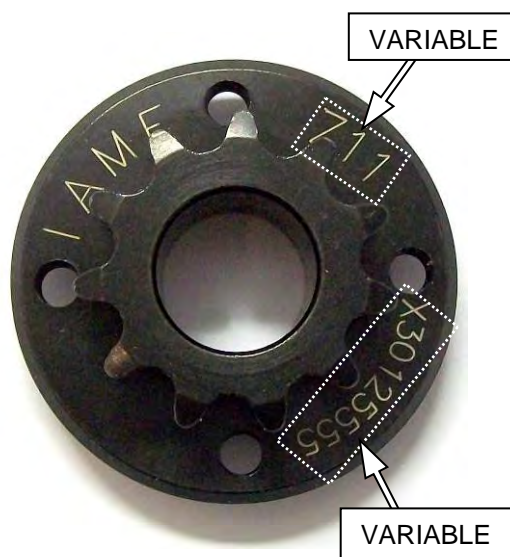

CLUTCH BODY IDENTIFICATION MARKING  
 MARQUAGE D'IDENTIFICATION DU CORPS  
 DE L'EMBRAYAGE

CLUTCH DRUM IDENTIFICATION MARKING  
 MARQUAGE D'IDENTIFICATION DE LA  
 CALOTTE

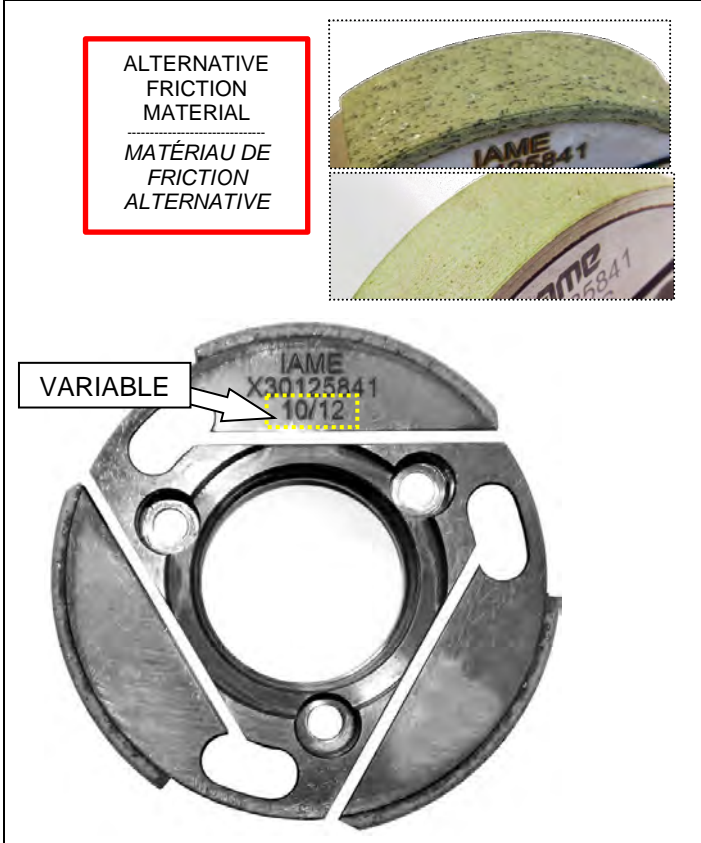

STARTER RING IDENTIFICATION MARKING  
 MARQUAGE D'IDENTIFICATION DE LA  
 COURONNE DE DEMARRAGE

STARTER IDENTIFICATION MARKING  
 MARQUAGE D'IDENTIFICATION DU  
 DEMARREUR

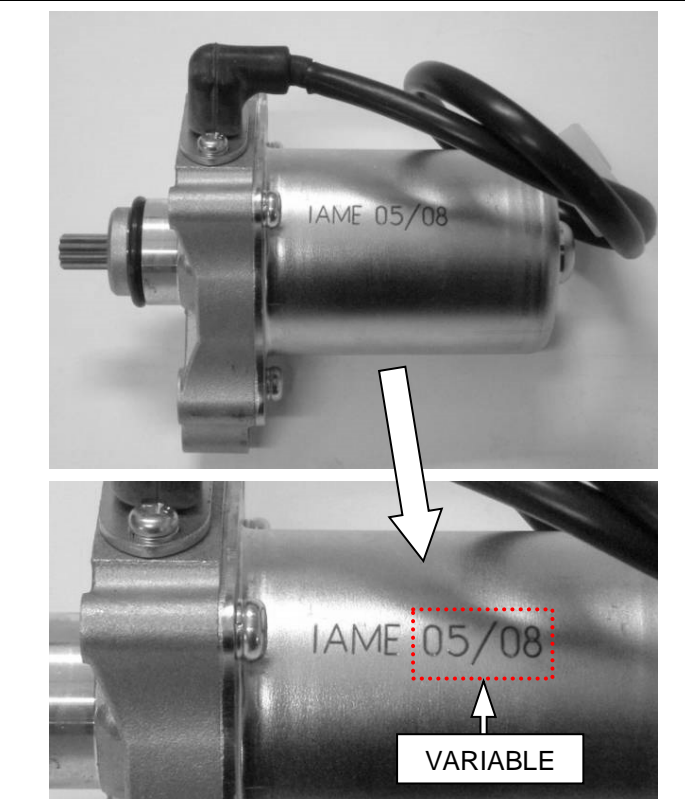
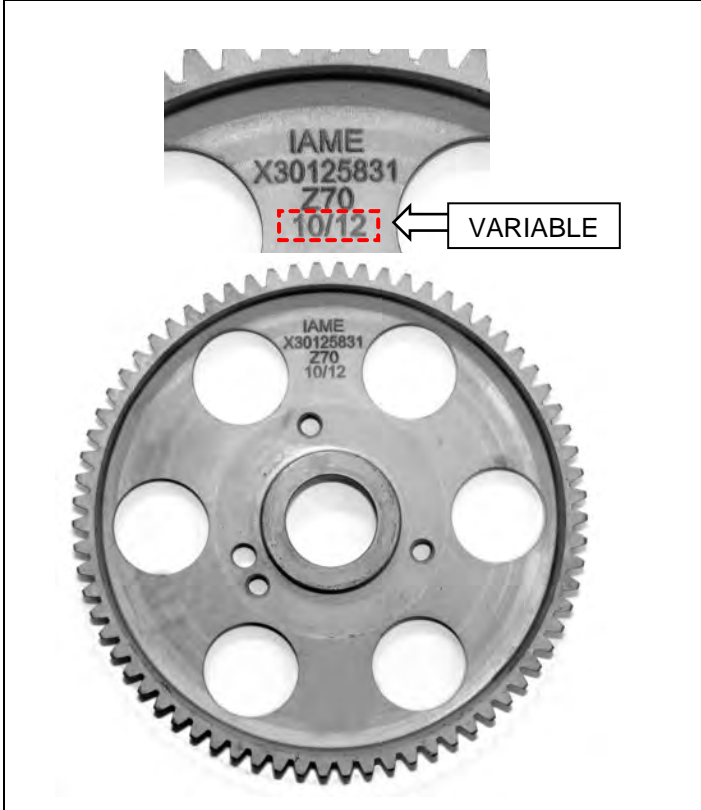

REED GROUP & PETALS IDENTIFICATION MARKING  
 MARQUAGE D'IDENTIFICATION DE LA BOÎTE À CLAPETS ET CLAPETS

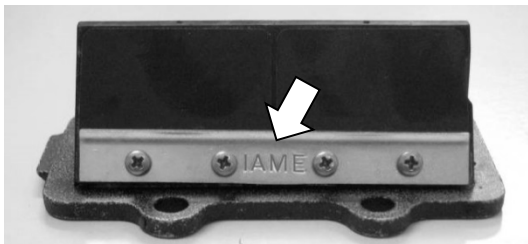
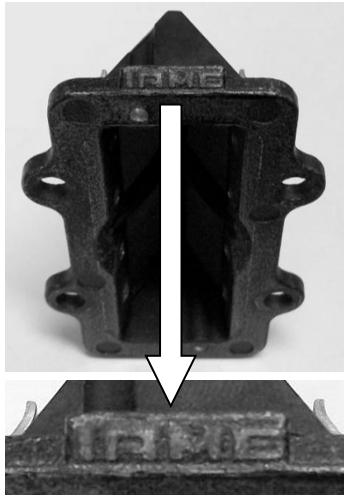

VETRONITE – FIBRE DE VERRE

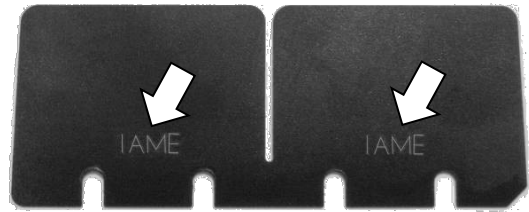

CARBON FIBER / FIBRE CARBONE

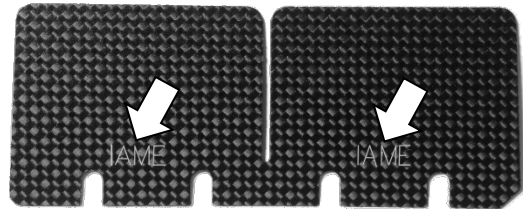

FRONT SIDE  
CÔTÉ AVANT

REAR SIDE  
CÔTÉ ARRIÈRE

PHOTO IDENTIFICATION CARBURETOR  
 INLET CONVEYOR  
 MARQUAGE D'IDENTIFICATION DU  
 COLLECTEUR D'ADMISSION

EXHAUST SILENCER IDENTIFICATION  
 MARKING  
 MARQUAGE D'IDENTIFICATION  
 ECHAPPEMENT

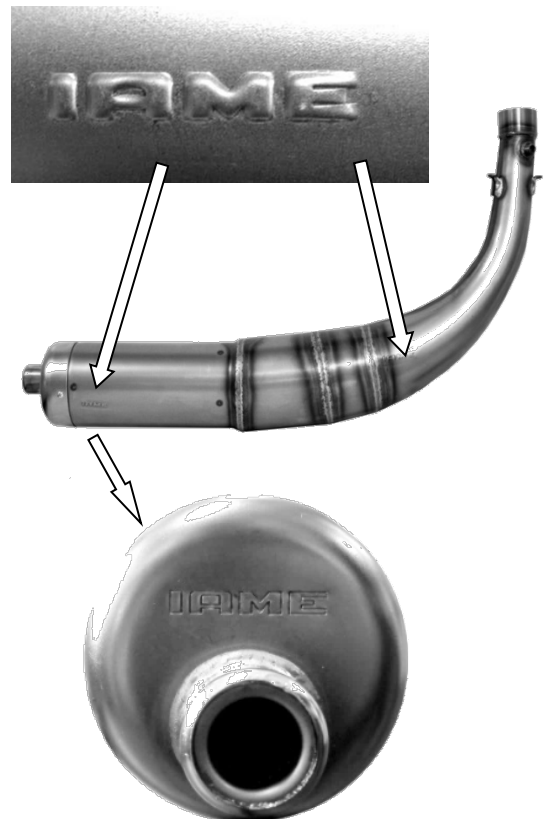

STATOR IDENTIFICATION MARKING  
MARQUAGE D'IDENTIFICATION DU STATOR

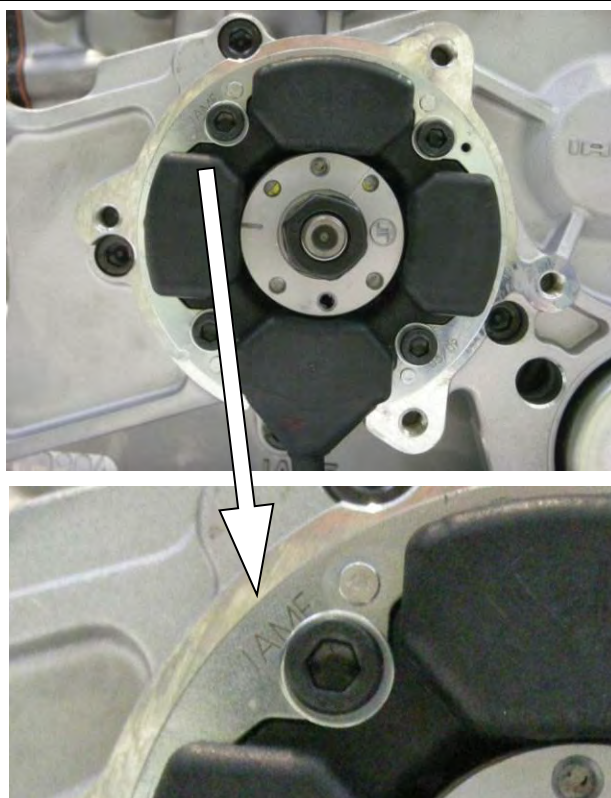

CLUTCH COVER AND H.T. COIL IDENTIFICATION MARKING  
MARQUAGE DU COUVERCLE D'EMBRAYAGE ET DE LA BOBINE

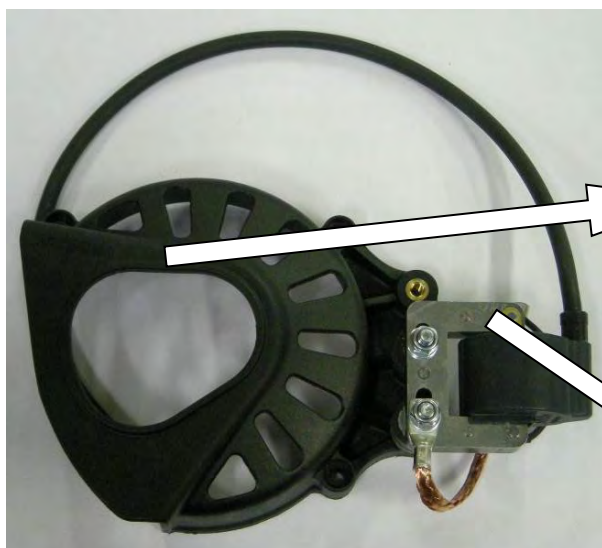

BENDIX COVER IDENTIFICATION MARKING  
MARQUAGE D'IDENTIFICATION DU COUVERCLE  
DU CONTRE-ARBRE DE DEMARRAGE

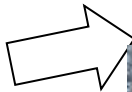
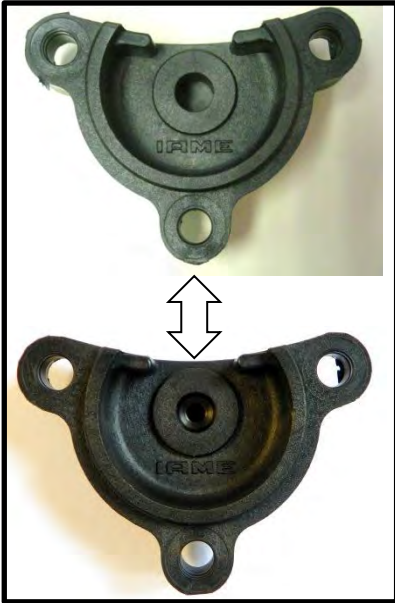

ALTERNATIVE



ALTERNATIVE RADIATOR IDENTIFICATION MARKING  
MARQUAGE ALTERNATIF D'IDENTIFICATION DU RADIATEUR

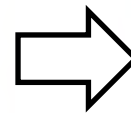
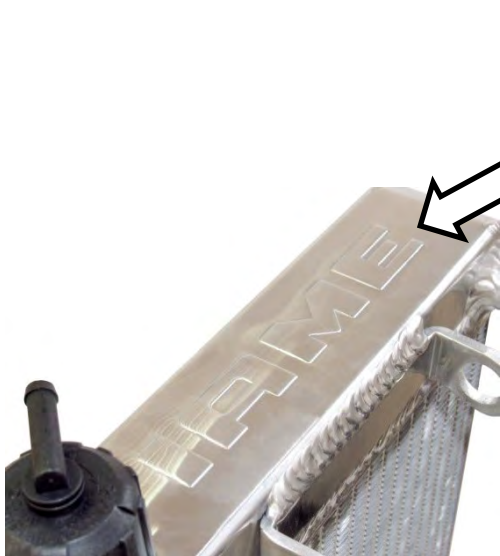

WIRING DIAGRAM ( SELETTRA DIGITAL "K" IGNITION 2013 )  
 SCHÉMA CIRCUIT ELECTRIQUE ( ALLUMAGE SELETTRA DIGITAL "K" 2013 )

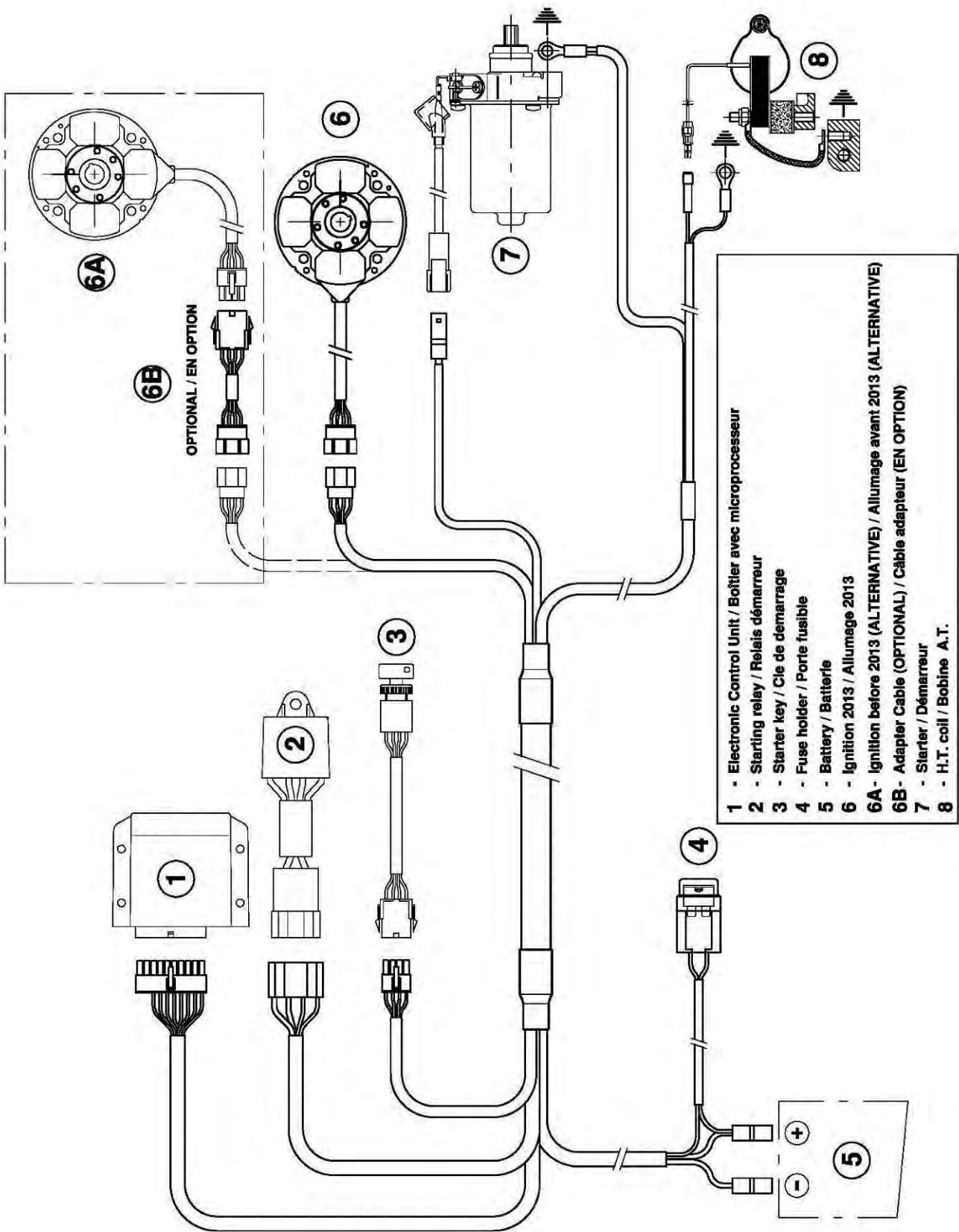

- 1 - Electronic Control Unit / Boîtier avec microprocesseur
- 2 - Starting relay / Relais démarrage
- 3 - Starter key / Cle de démarrage
- 4 - Fuse holder / Porte fusible
- 5 - Battery / Batterie
- 6 - Ignition 2013 / Allumage 2013
- 6A - Ignition before 2013 (ALTERNATIVE) / Allumage avant 2013 (ALTERNATIVE)
- 6B - Adapter Cable (OPTIONAL) / Câble adaptateur (EN OPTION)
- 7 - Starter / Démarrreur
- 8 - H.T. coil / Bobine A.T.

# FROM 2014 ON - A PARTIR DE 2014

STICKER APPLICATION AREA - ESPACE POUR L'APPLICATION DES ADHÉSIFS

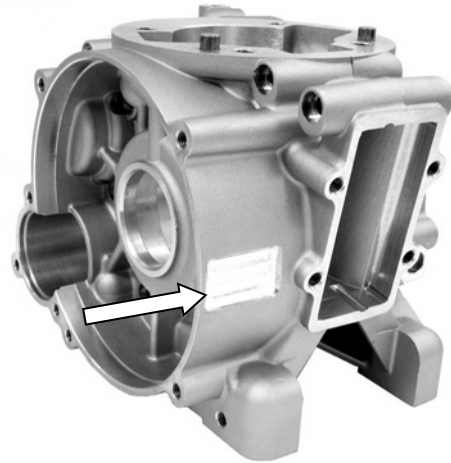
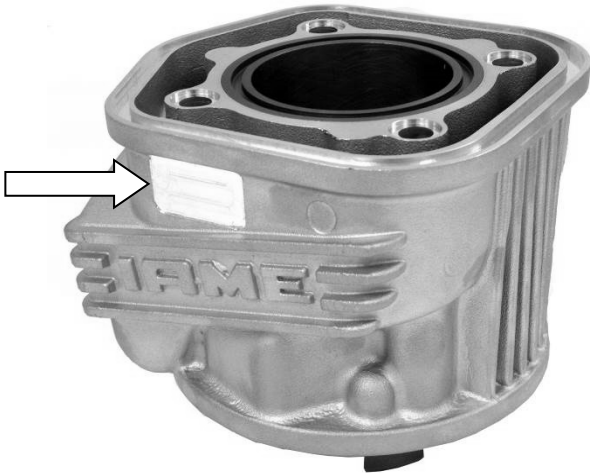

ALTERNATIVE AREA / ZONE ALTERNATIVE

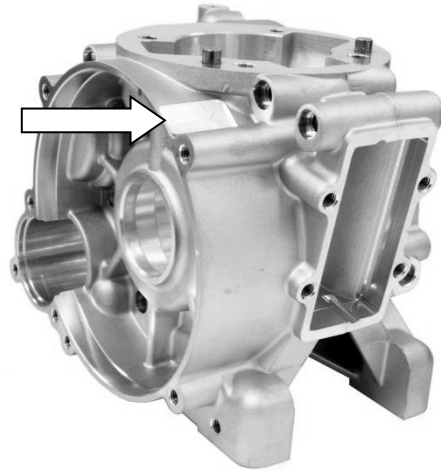

## EXHAUST TEMPERATURE SENSOR CAPTEUR DE TEMPERATURE D'ÉCHAPPEMENT

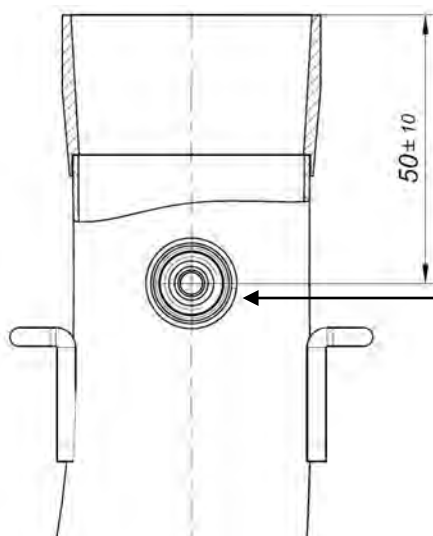

EXHAUST  
TEMPERATURE  
SENSOR POSITION  
(OPTIONAL)

POSITION DU  
CAPTEUR  
DE TEMPERATURE  
D'ÉCHAPPEMENT  
(EN OPTION)

CYLINDER IDENTIFICATION MARKING  
MARQUAGE D'IDENTIFICATION DU CYLINDRE

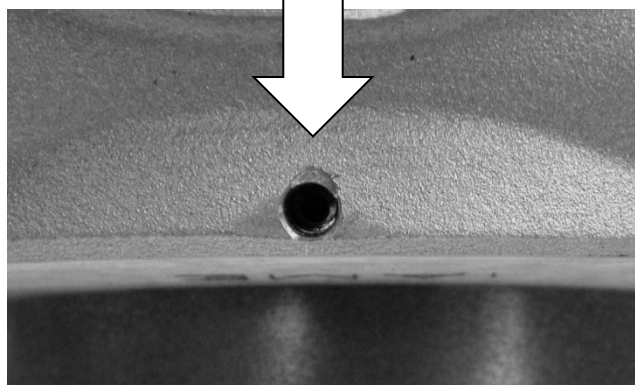
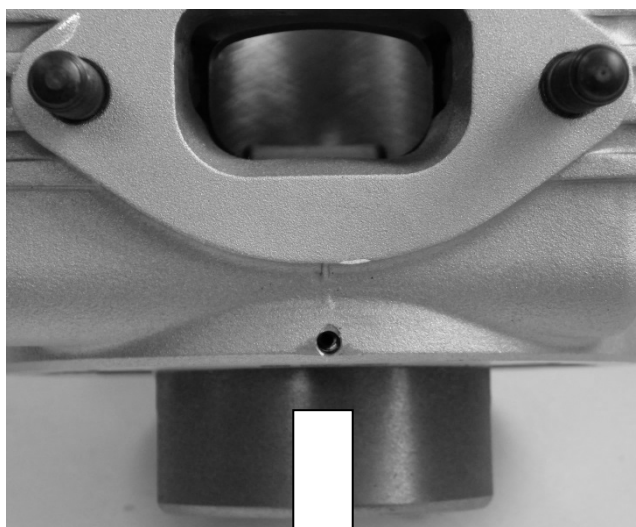
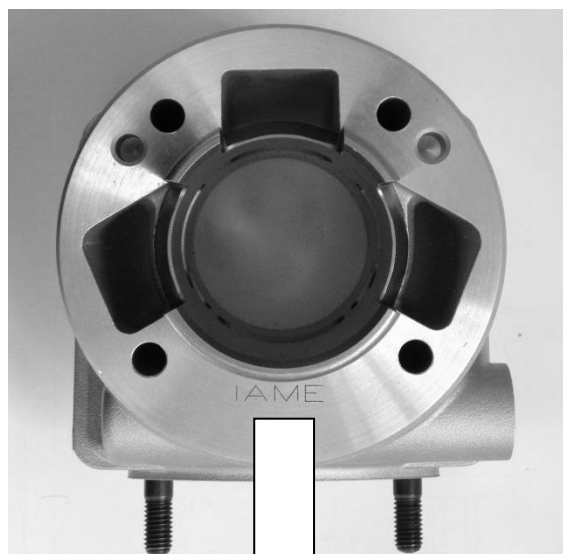
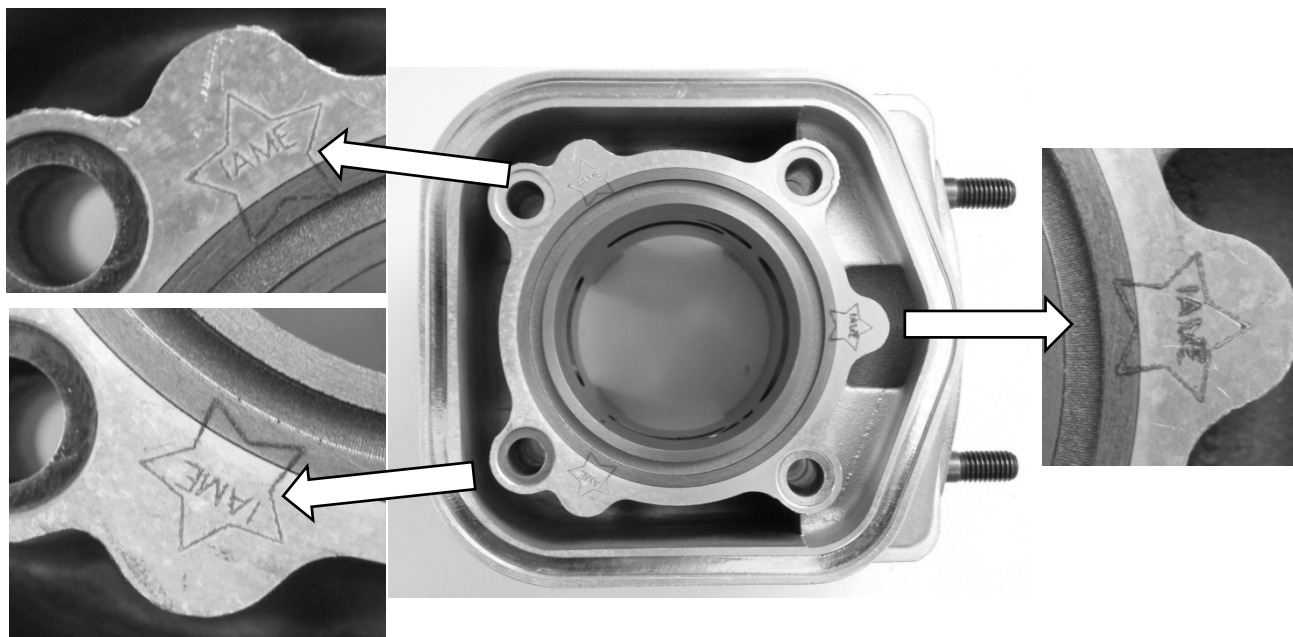



CYLINDER BASE ALTERNATIVE MARKING  
MARQUAGE ALTERNATIF DE LA BASE DU CYLINDRE

**ALTERNATIVE**

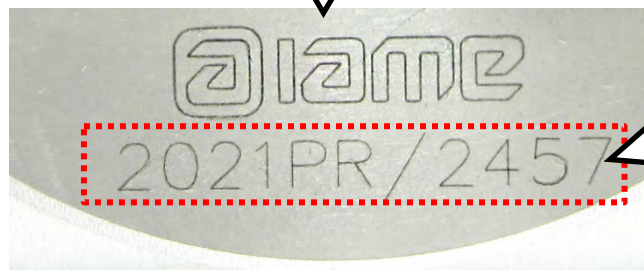
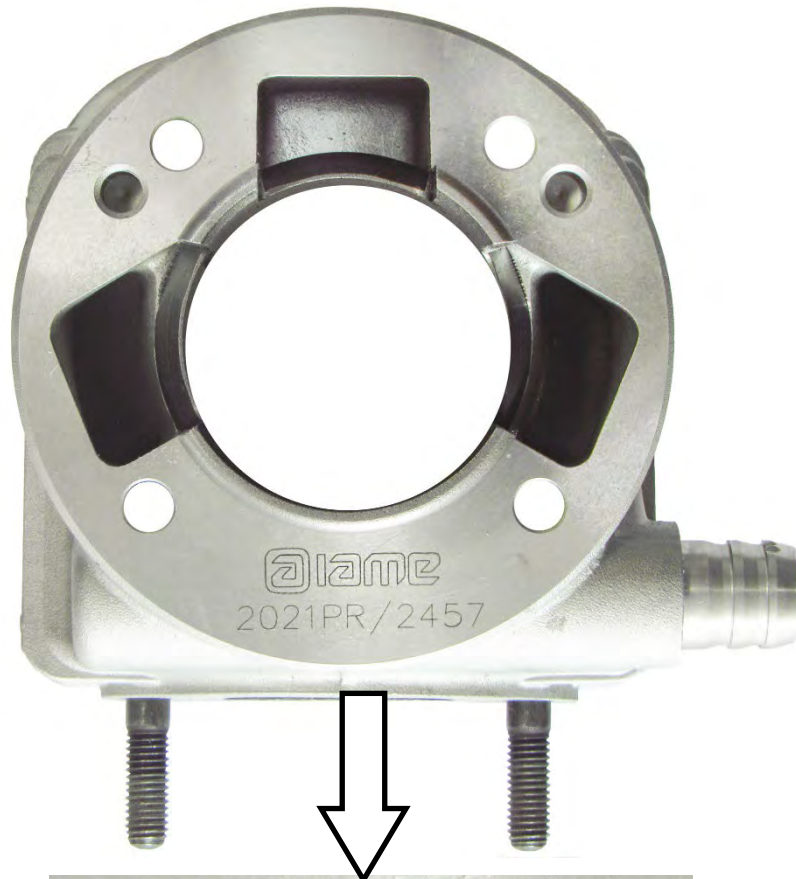

**VARIABLE**

ALTERNATIVE PUSH BUTTONS – START & STOP  
BOUTONS ALTERNATIF “START & STOP” DU DEMARREUR

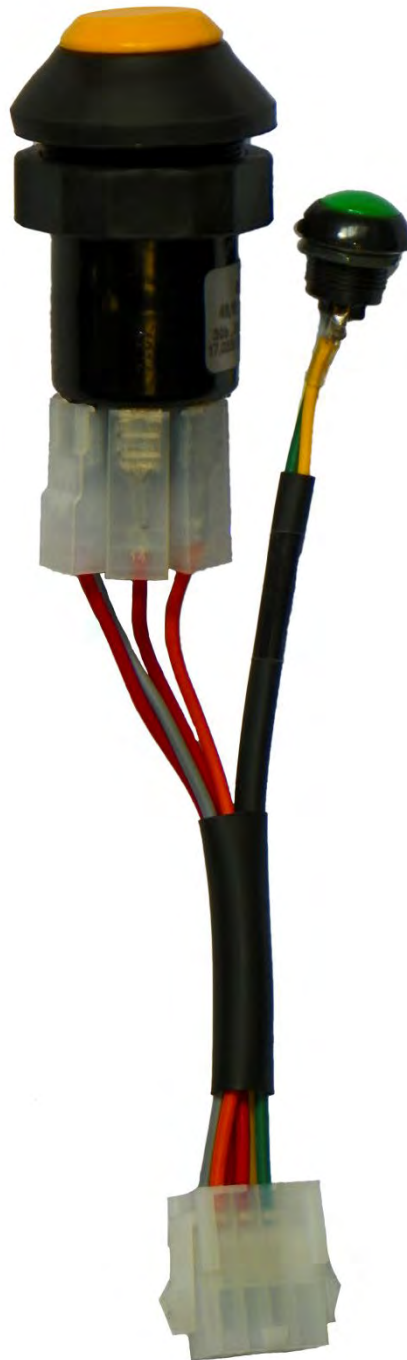
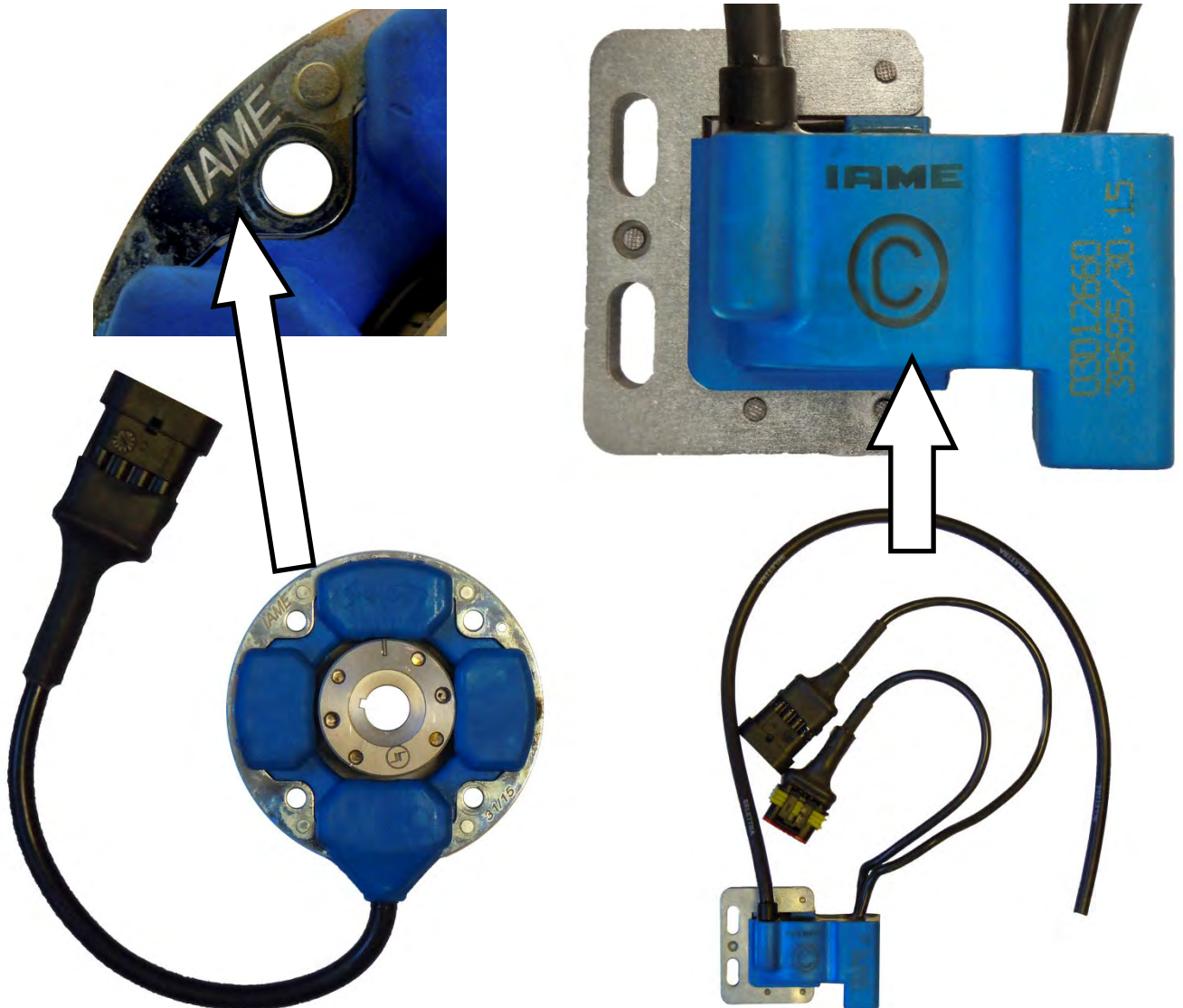

PHOTO COMPLETE ALTERNATIVE WIRING LOOM  
PHOTO DU CABLAGE ELECTRIQUE COMPLET ALTERNATIF



PHOTO OF SELETTRA ALTERNATIVE DIGITAL "S" IGNITION, WITH IAME MARKING  
PHOTO DE L'ALLUMAGE SELETTRA DIGITAL "S", AVEC MARQUAGE IAME



WIRING DIAGRAM ( SELETTRA DIGITAL "S" IGNITION )  
 SCHÉMA CIRCUIT ELECTRIQUE ( ALLUMAGE SELETTRA DIGITAL "S" )

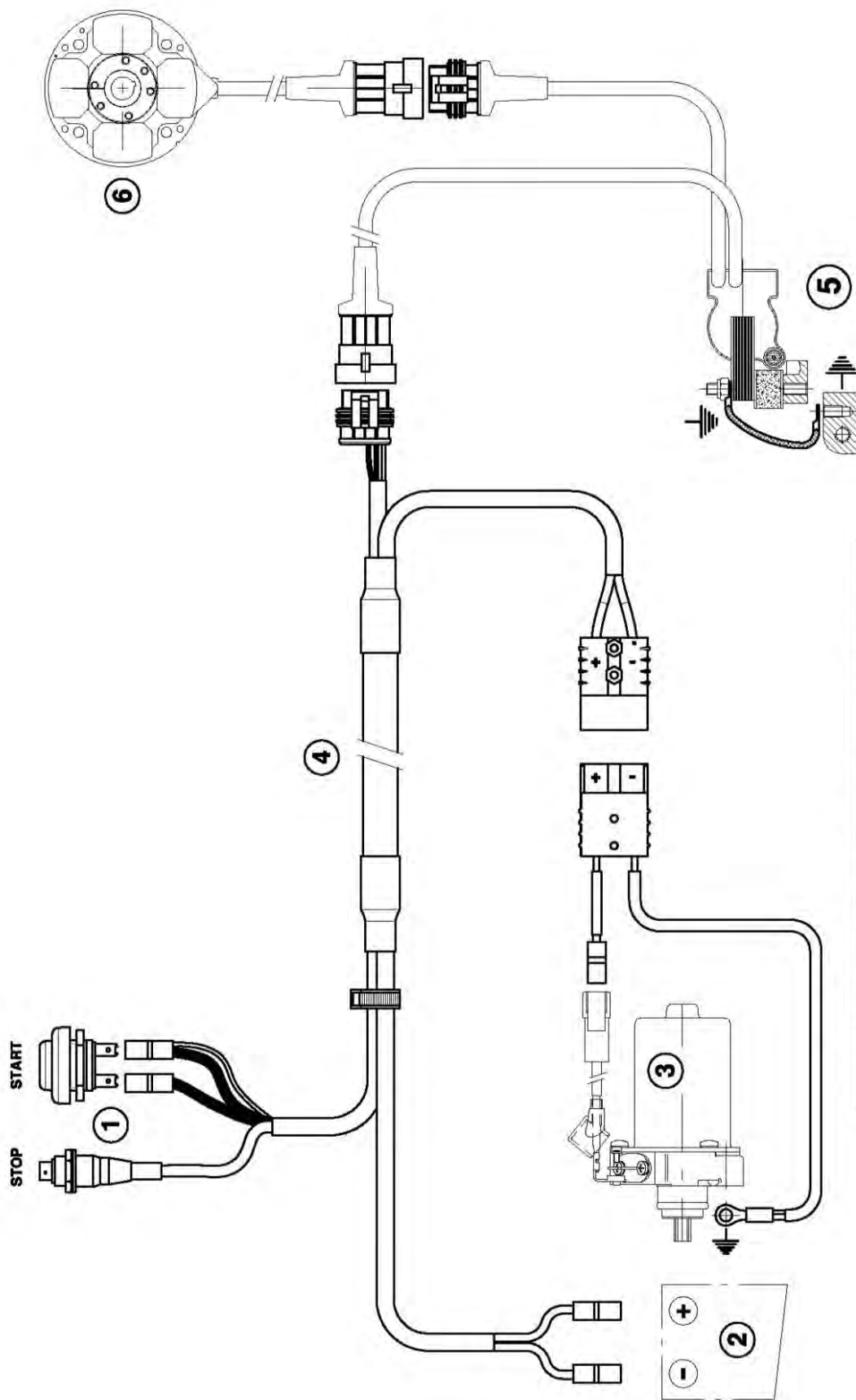

- 1 - Push buttons Start & Stop / Bouton poussoir du démarreur
- 2 - Battery / Batterie
- 3 - Starter / Démarreur
- 4 - Wiring cable / Cablage électrique
- 5 - H.T. coil and Electronic Control Unit / Bobine A.T. et boîtier avec microprocesseur
- 6 - Ignition / Allumage

ALTERNATIVE WIRING LOOM  
CABLAGE ELECTRIQUE COMPLET ALTERNATIF



ALTERNATIVE WIRING LOOM DIAGRAM  
SCHÉMA CIRCUIT ELECTRIQUE ALTERNATIF

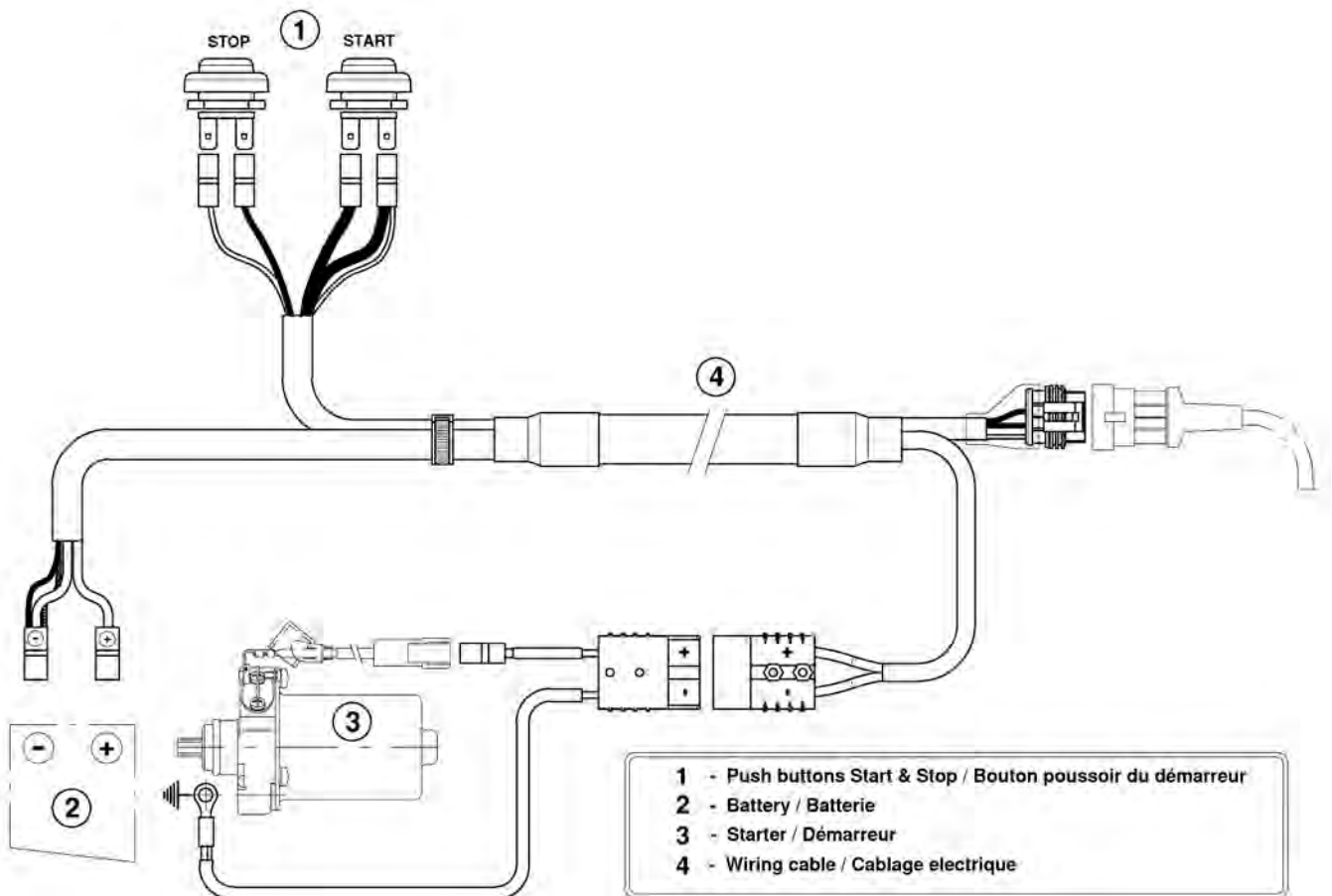

ALTERNATIVE WIRING LOOM  
CABLAGE ELECTRIQUE COMPLET ALTERNATIF

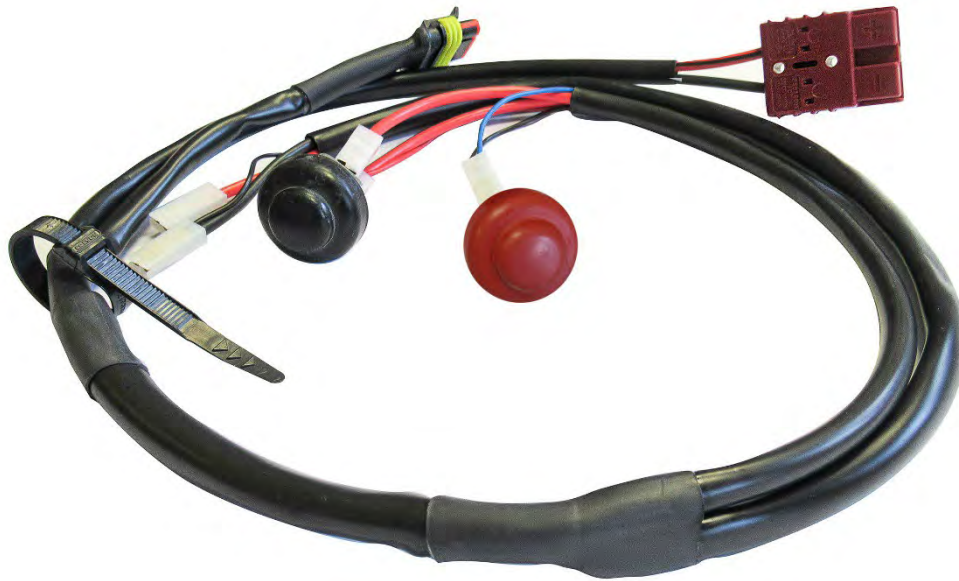

ALTERNATIVE WIRING LOOM DIAGRAM  
SCHÉMA CIRCUIT ELECTRIQUE ALTERNATIF

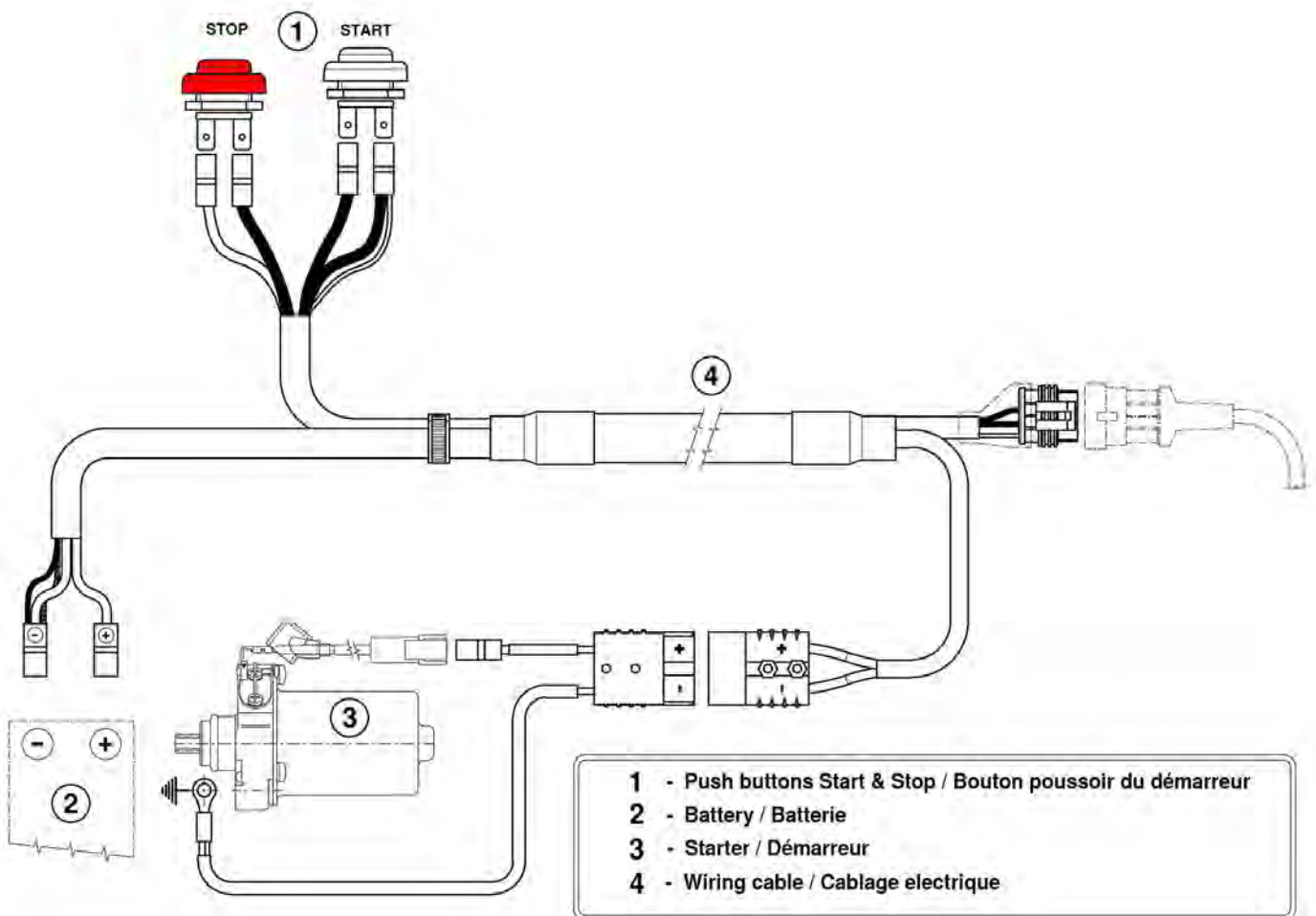
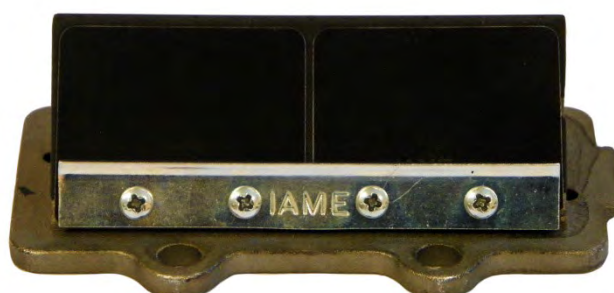
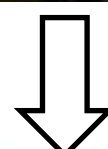
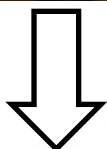

PHOTO IDENTIFICATION REED GROUP  
PHOTO IDENTIFICATION BOÎTE À CLAPETS

ACTUAL VERSION  
VERSION COURANTE

ALTERNATIVE VERSION  
VERSION ALTERNATIVE



ACTUAL PISTON  
PISTON COURANT

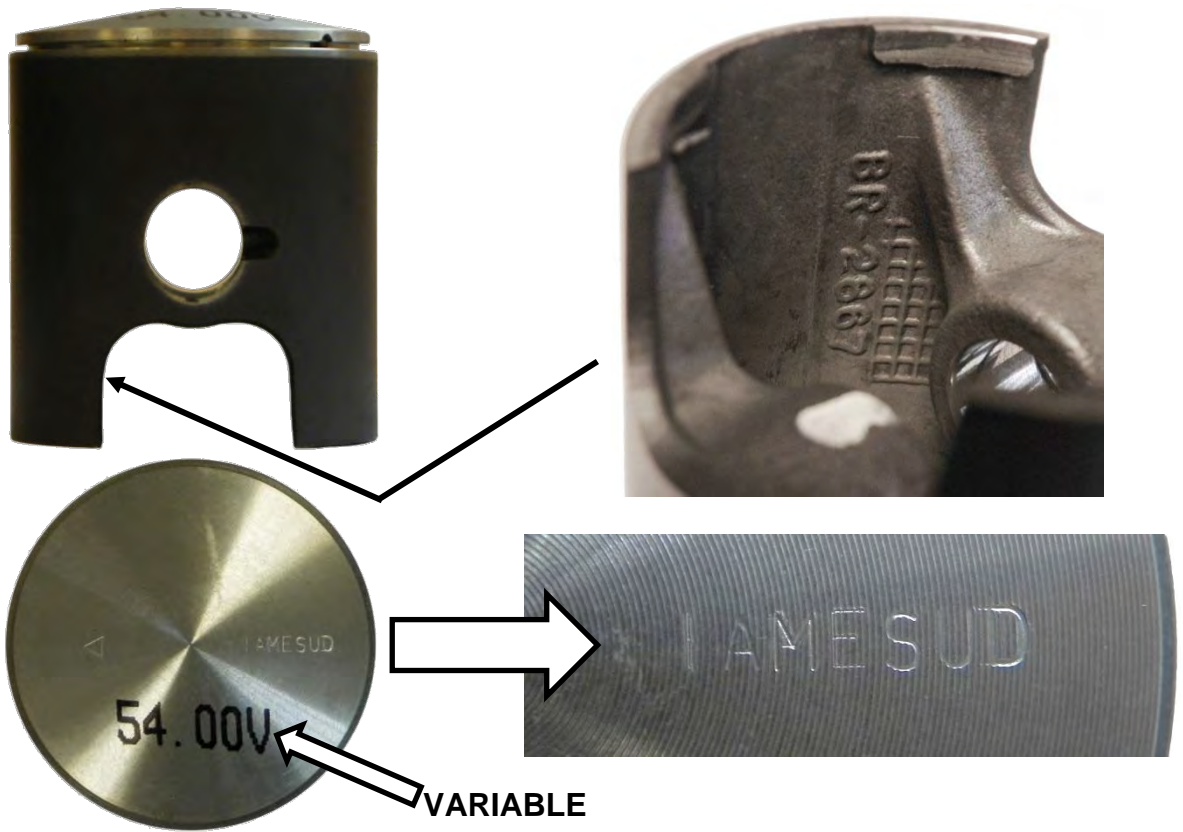

ALTERNATIVE PISTON  
PISTON ALTERNATIF

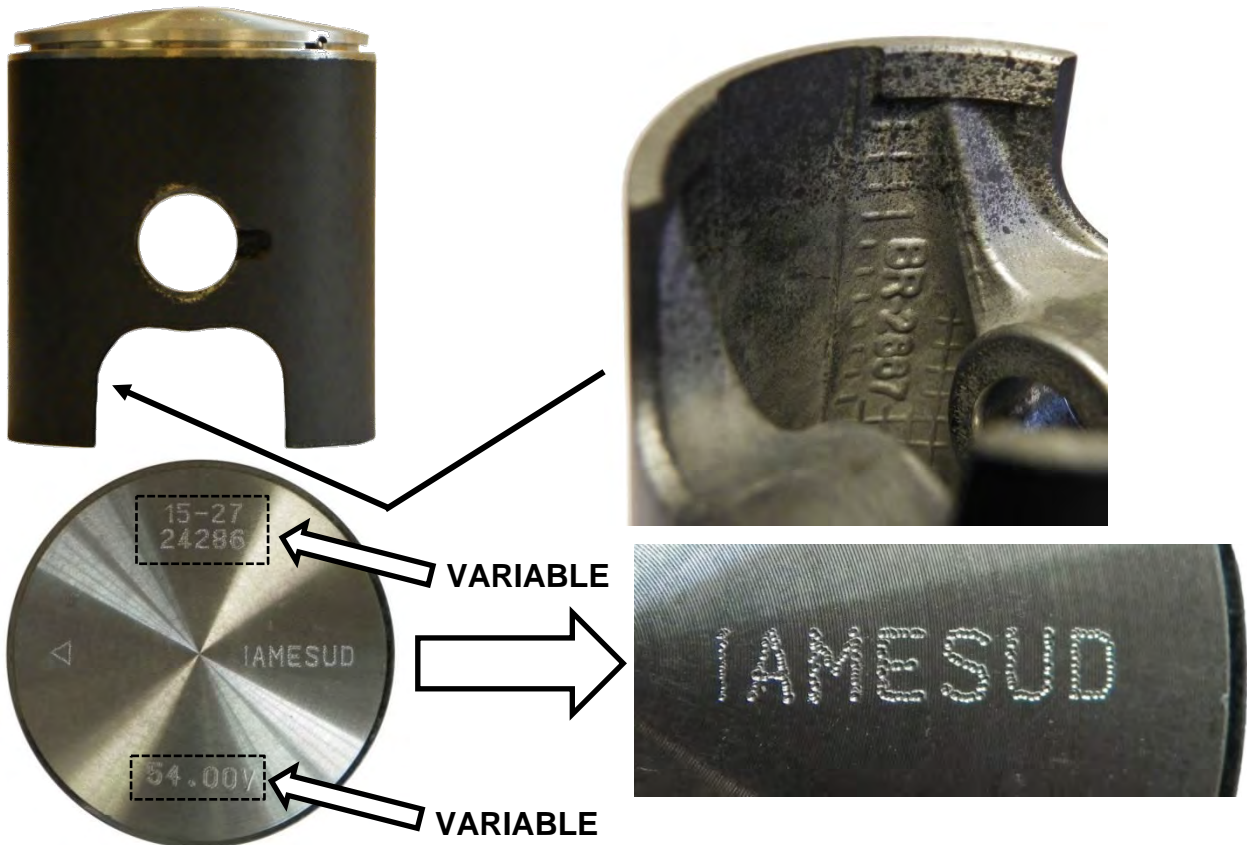



ALTERNATIVE CONROD  
BIELLE ALTERNATIVE

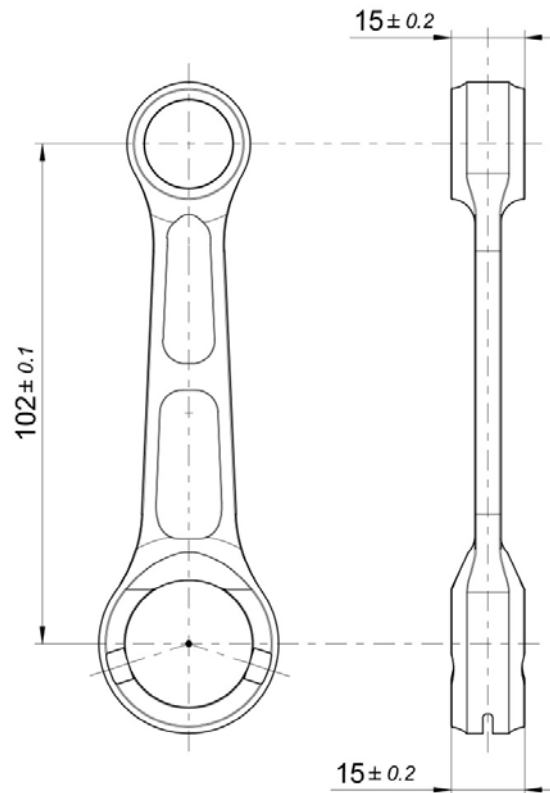
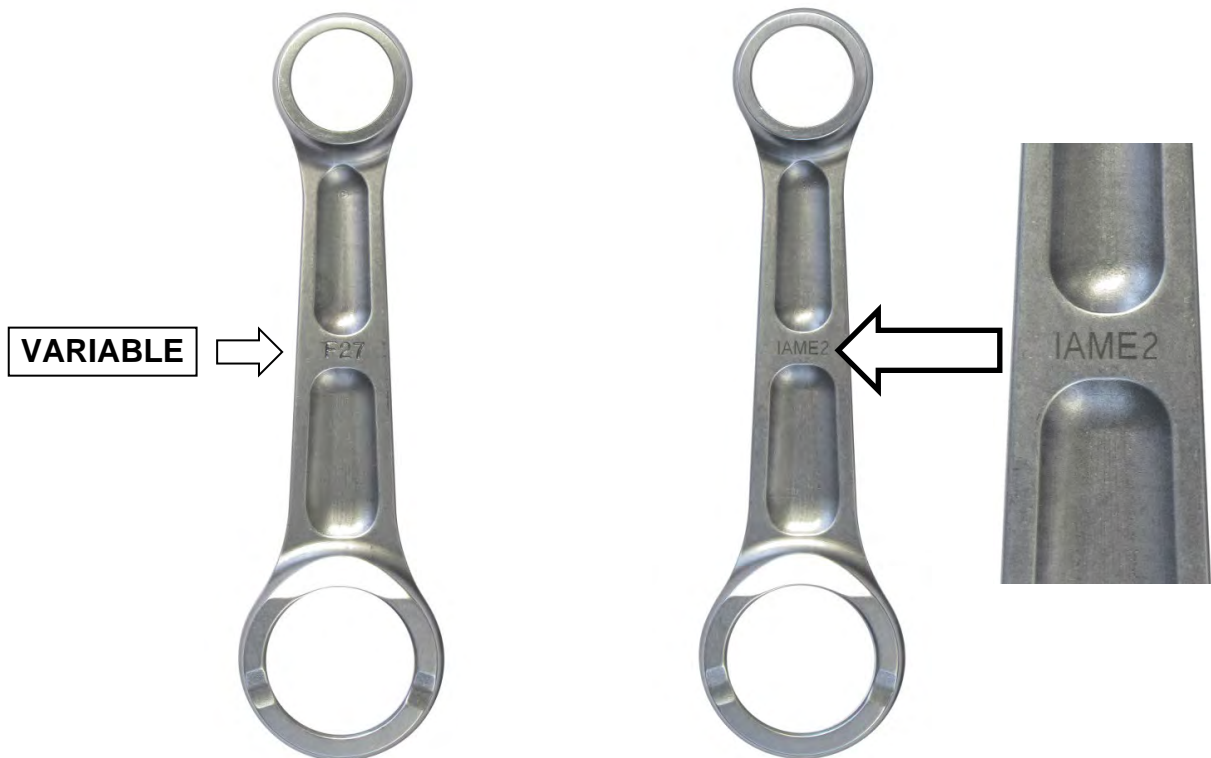

PHOTO OF THE CONROD BOTH SIDE – ALTERNATIVE  
PHOTO DES DEUX COTES DE LA BIELLE - ALTERNATIVE



**BOTH TYPES OF CONROD CAN BE USED WITH BOTH TYPES OF WASHERS (IN COUPLE)  
LES DEUX TYPES DE BIELLE PEUVENT ÊTRE UTILISÉS AVEC LES DEUX TYPES DE  
RONDELLES (EN COUPLE)**

PHOTO IDENTIFICATION OF SMALL END CONROD BEARING – TYPES ALTERNATIVE  
*PHOTO D'IDENTIFICATION DU ROULEMENT PIED DE BIELLE – TYPES ALTERNATIFS*

TYPE 1



TYPE 2



PHOTO IDENTIFICATION OF CONROD WASHER – TYPES ALTERNATIVE  
*PHOTO D'IDENTIFICATION RONDELLE DE BIELLE – TYPES ALTERNATIVES*







TYPE 1



TYPE 2

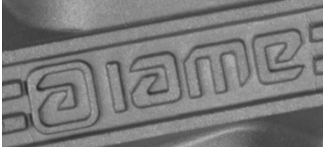

**PARTS WITH ALTERNATIVE NEW LOGO "IAME"**  
**COMPOSANTS AVEC UN NOUVEAU LOGO ALTERNATIF «IAME»**

<p align="center">CYLINDER HEAD CULASSE</p>  <p align="center"><b>NEW / NOUVEAU LOGO</b></p> 	<p align="center">CYLINDER CYLINDRE</p>  <p align="center"><b>NEW / NOUVEAU LOGO</b></p> 
<p align="center">SEMICARTER TRANSMISSION SIDE DEMI-CARTER CÔTÉ PIGNON</p>  <p align="center"><b>NEW / NOUVEAU LOGO</b></p> 	<p align="center">SEMICARTER IGNITION SIDE DEMI-CARTER CÔTÉ ALLUMAGE</p>  <p align="center"><b>NEW / NOUVEAU LOGO</b></p> 

**PARTS WITH ALTERNATIVE NEW LOGO "IAME"**  
**COMPOSANTS AVEC UN NOUVEAU LOGO ALTERNATIF «IAME»**

IGNITION COVER  
COUVERCLE DE L'ALLUMAGE

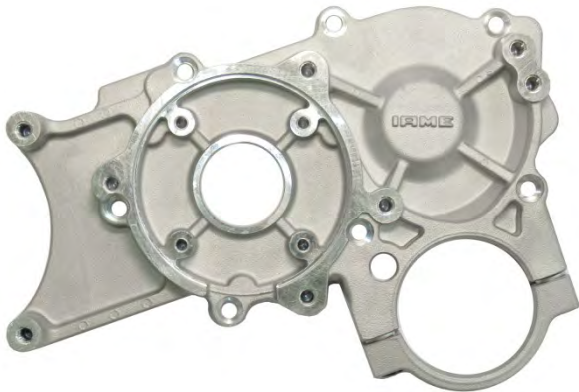

**NEW / NOUVEAU LOGO**

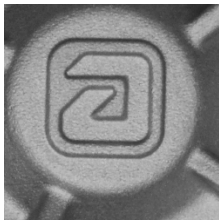

CLUTCH COVER  
COUVERCLE D'EMBAYAGE



**NEW / NOUVEAU LOGO**



REED GROUP  
GROUPE CLAPETS



**NEW / NOUVEAU LOGO**





CARBURETTOR INLET CONVEYOR  
CONVOYEUR D'ADMISSION



**NEW / NOUVEAU LOGO**



**PARTS WITH ALTERNATIVE NEW LOGO "IAME"**  
**COMPOSANTS AVEC UN NOUVEAU LOGO ALTERNATIF «IAME»**

<p align="center">RADIATOR RADIATEUR</p>	<p align="center">EXHAUST SILENCER ECHAPPEMENT</p>
<p align="center">NEW / NOUVEAU LOGO</p>  <p>The image shows a rectangular radiator with a black top cap and a black bottom base. To its right is a vertical rectangular plate with the 'IAME' logo embossed in a stylized, bold font.</p>	<p align="center">NEW / NOUVEAU LOGO</p>  <p>The image shows a curved metal exhaust silencer. Above it is a rectangular plate with the 'IAME' logo embossed. Below the silencer is a circular metal component with the 'IAME' logo embossed on its top surface. Below that is another rectangular plate with the 'IAME' logo embossed.</p>
<p align="center">BALANCING SHAFT ARBRE D'EQUILIBRAGE</p>	
<p align="center">NEW / NOUVEAU LOGO</p>  <p>The image shows a balancing shaft component. Above it is a rectangular plate with the 'IAME' logo embossed. A large white arrow points from the logo plate down to the shaft. The shaft is a metal component with a cylindrical end and a threaded section.</p>	

**THE OTHERS COMPONENTS OF ENGINE THAT ARE MARKED (LASER OR PUNCHING) UNTIL TODAY WITH LOGO OR WRITTEN "IAME"**

**LES AUTRES COMPOSANTS DU MOTEUR AVEC COMME MARQUAGE (LASER OU POINÇONNEUSE) L'ANCIEN LOGO OU ÉCRIT «IAME»**

I A M E

or

**IAME**

**NOW COULD BE MARKED WITH NEW LOGO "IAME"**

**POURRAIENT MAINTENANT ETRE MARQUES AVEC LE NOUVEAU LOGO "IAME"**

ia me

or

ia me

or

ia

CHECKING THE SHAPE OF THE COMBUSTION CHAMBER  
CONTRÔLE DE LA FORME DE LA CHAMBRE DE COMBUSTION

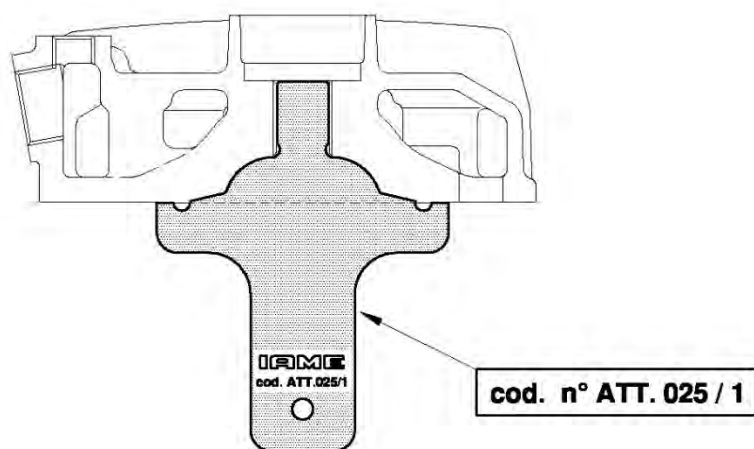

CONTROL OF THE PISTON DOME  
CONTRÔLE DU DÔME DE PISTON

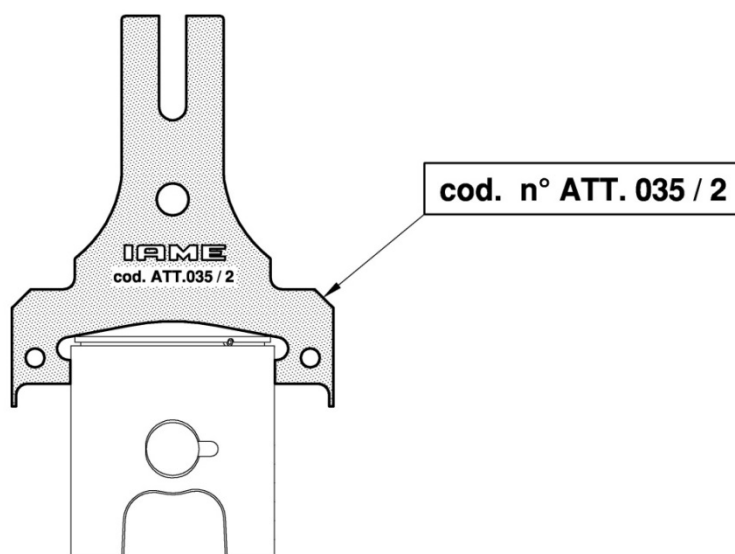

CONTROL OF THE VOLUME OF THE COMBUSTION CHAMBER  
CONTRÔLE DU VOLUME DE LA CHAMBRE DE COMBUSTION

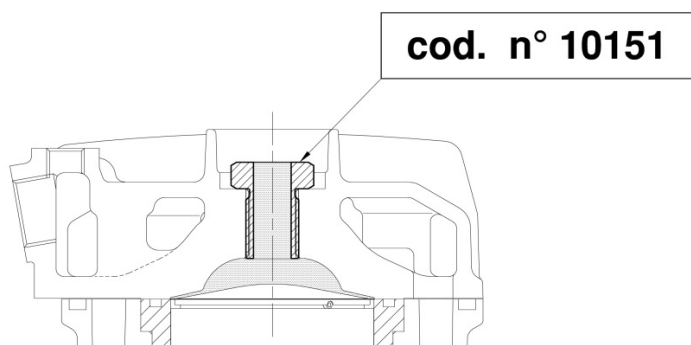

**CYLINDER CHECK - CONTRÔLE DU CYLINDRE**  
**CHECKING OF EXHAUST DUCT AND LATERAL TRANSFERS**  
**CONTRÔLE DE LA LUMIÈRE D'ÉCHAPPEMENT ET DES TRANSFERTS LATÉRAUX**

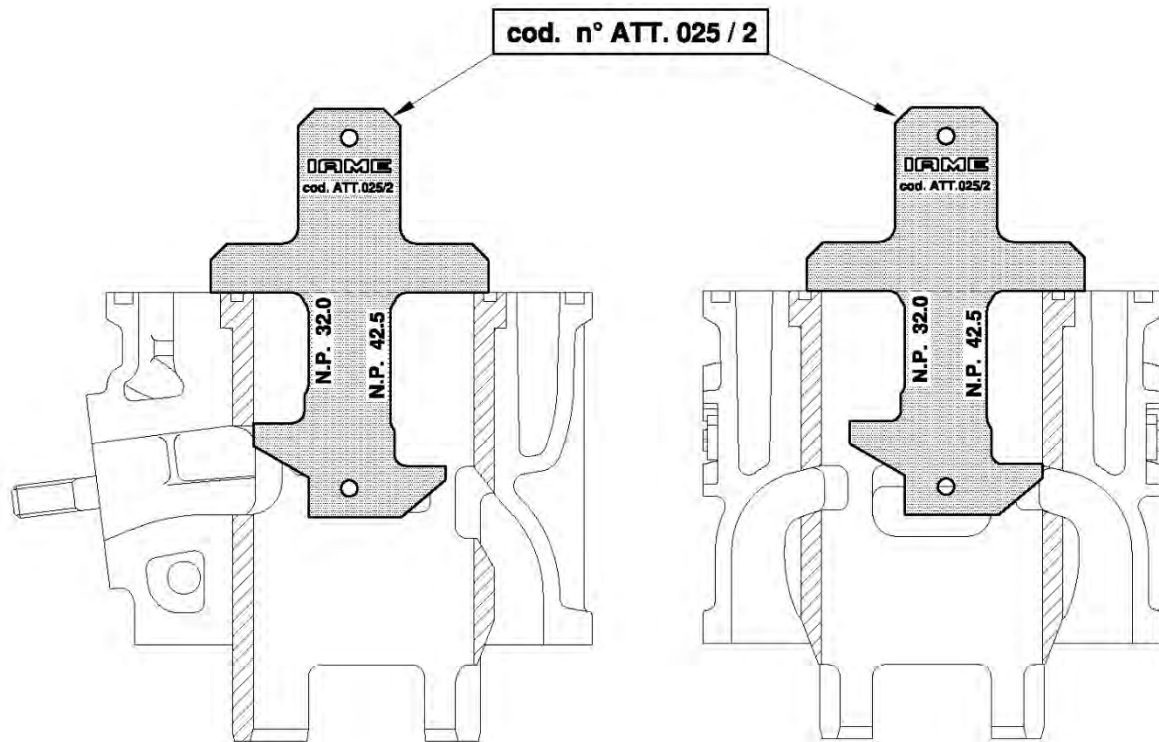

**CYLINDER LINER DUCTS AND TRANSFERS CHECKING TOOL**  
**OUTIL DE VÉRIFICATION DES LUMIÈRES DE LA CHEMISE DU CYLINDRE**

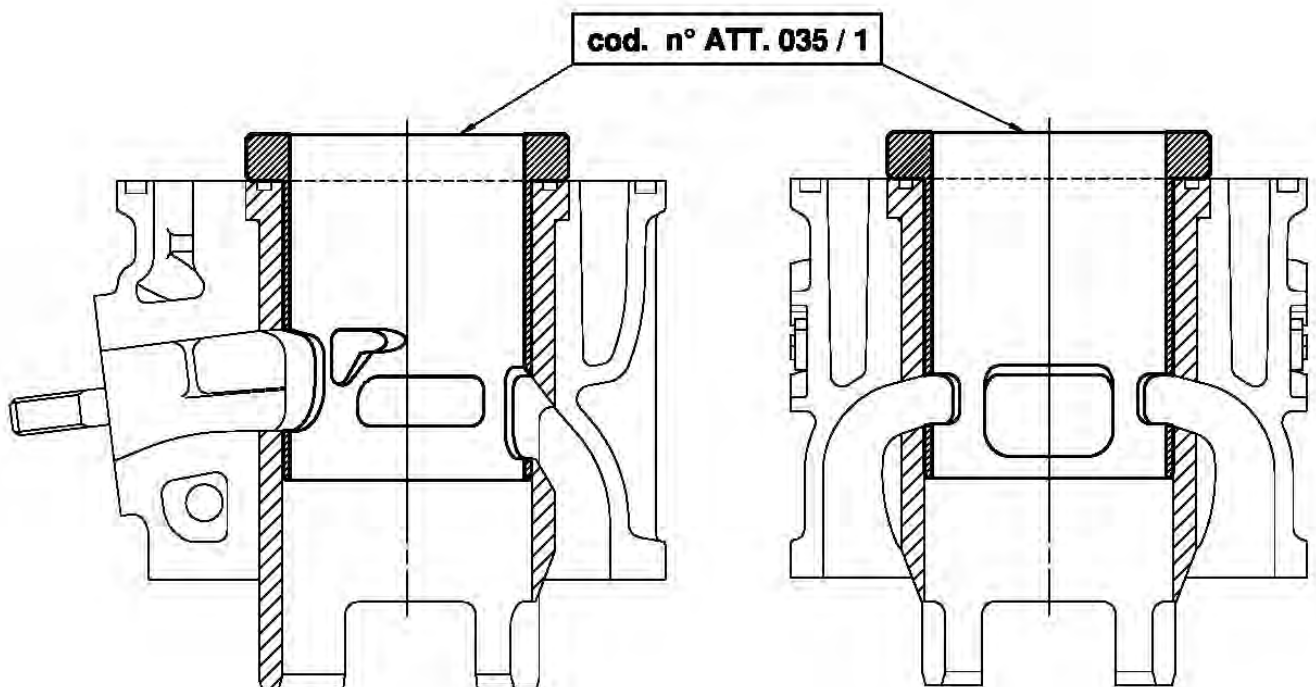



**CLUTCH DRUM CHECKING TOOL**  
**CONTRÔLE DE LA CLOCHE D'EMBRAYAGE**

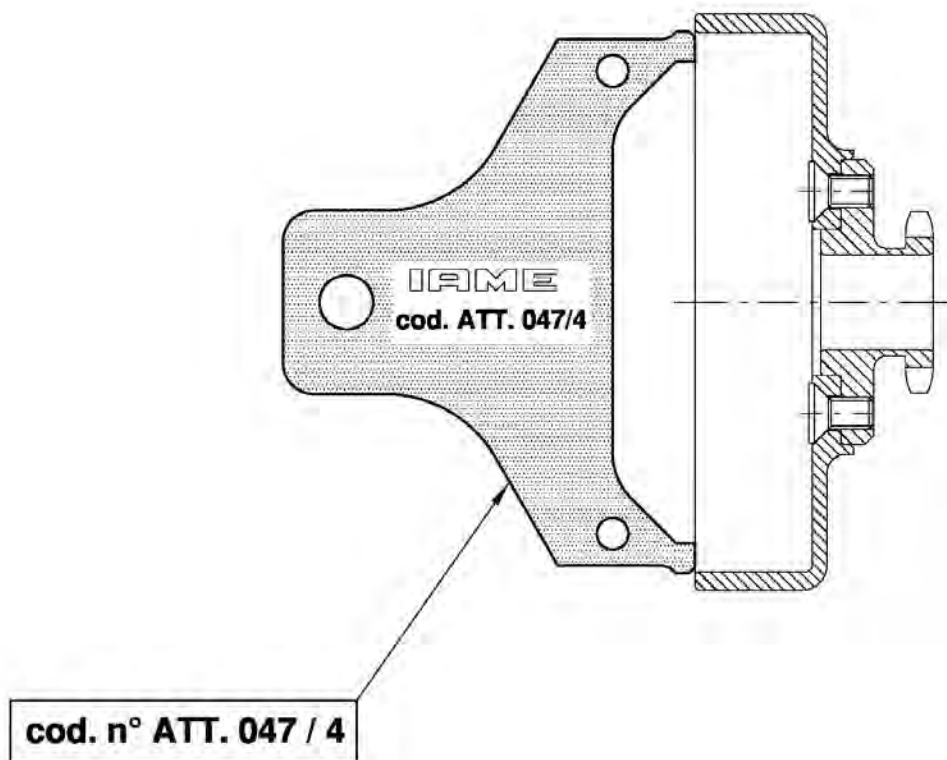

**CRANKCASE CHECKING TOOLS - CONTRÔLE DU CARTER**

**CHECKING THE INTERAXLE OF THE CILYNDER PINS**  
**CONTRÔLE DE L'ENTRAXE DES PIONS DE CENTRAGE DU CYLINDRE**

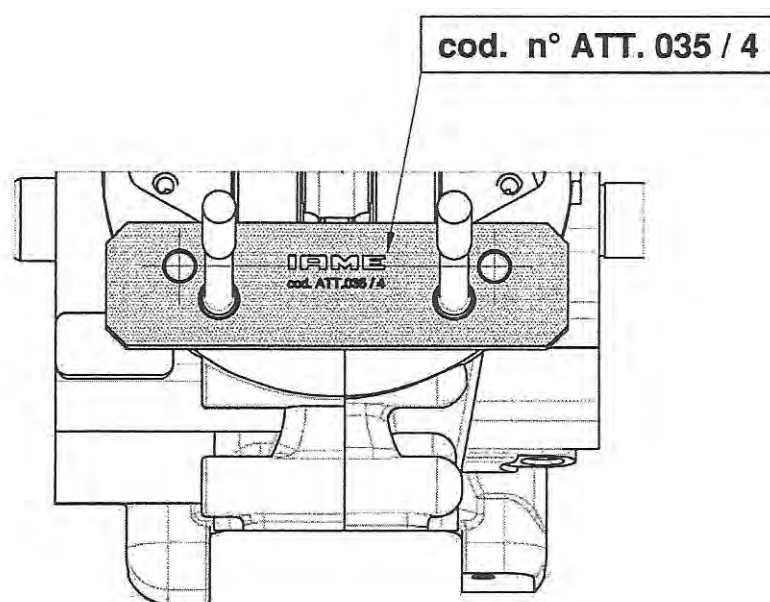

CONTROL OF THE HEIGHT OF THE CRANKSHAFT CYLINDER PLANE  
CONTRÔLE DE LA HAUTEUR DU PLAN CYLINDRE SUR LE CARTER

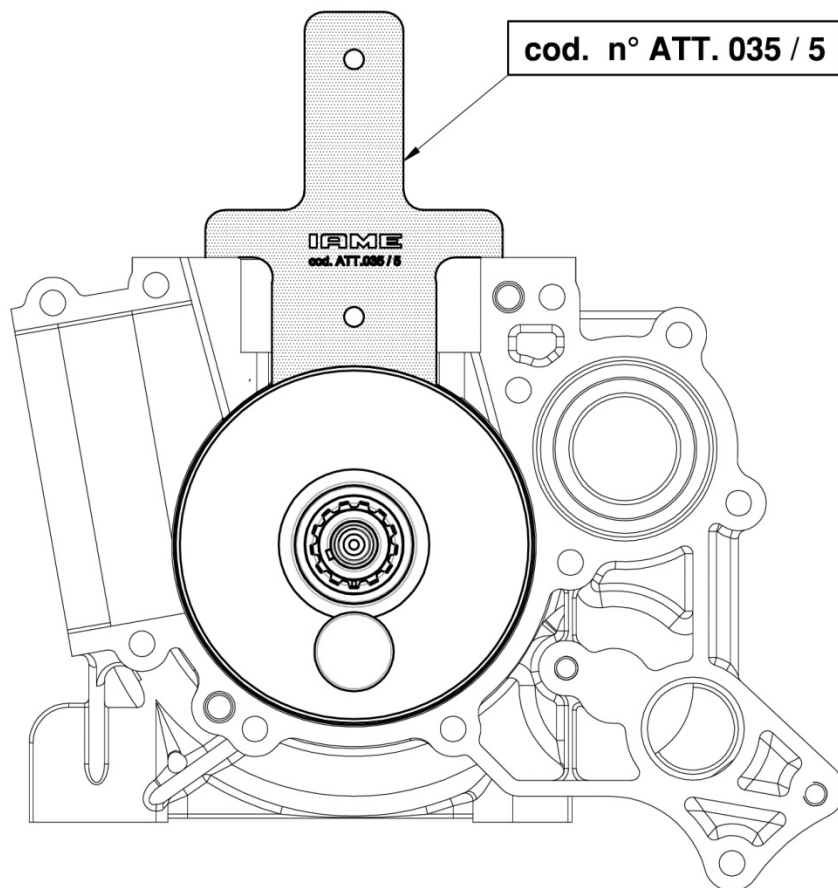

CHECKING OF THE REEDS VALVE PLANE  
CONTRÔLE DU PLAN DU LOGEMENT DE LA BOITE À CLAPETS

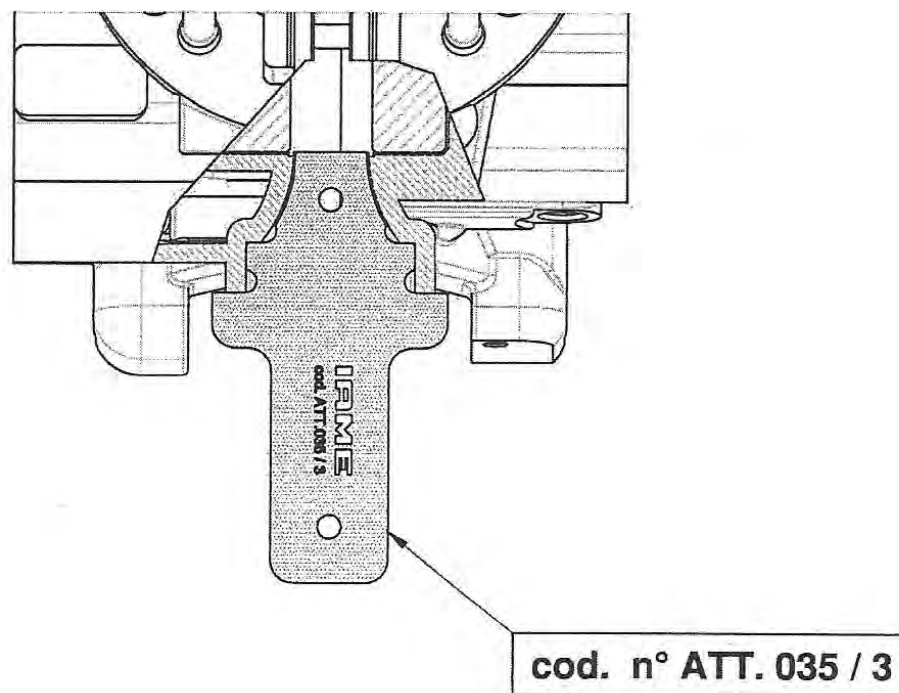

CHECKING OF THE POSITION OF SELETTRA DIGITAL "S" PHASE MARKING  
CONTRÔLE DE LA POSITION DU MARQUAGE DE PHASE  
SELETTRA DIGITAL "S"

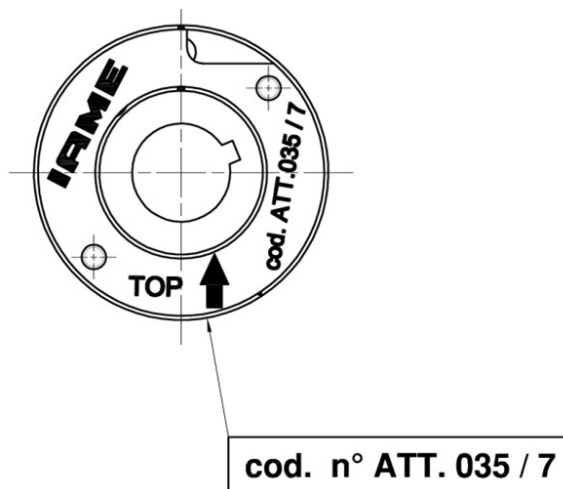

VENTURI SHAPE CONTROL OF TILLOTSON HW-27A CARBURETTOR  
CONTRÔLE DU VENTURI DU CARBURATEUR TILLOTSON HW-27A

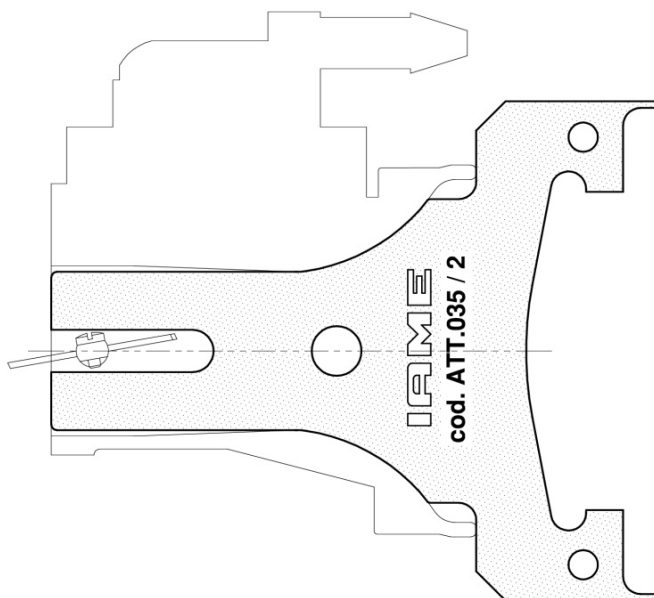

**CHECKING OF THE HEIGHT OF THE ATOMISER – GO IF IT'S OK**  
**CONTRÔLE DE LA HAUTEUR DU PULVERISATEUR**  
**IL PASSE S'IL EST CONFORME**

**ATT.035 / 12**

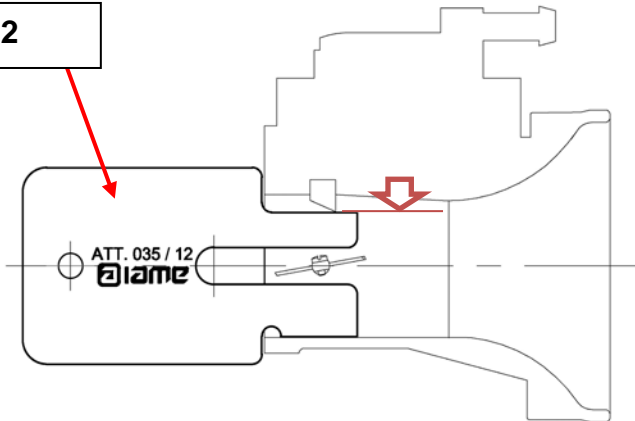

**CHECK HOLE OF ATOMIZER**  
**OUTIL DE VÉRIFICATION DE TROU DU PULVERISATEUR**

**Pass Side – OK**  
**Côté passe - Conforme**

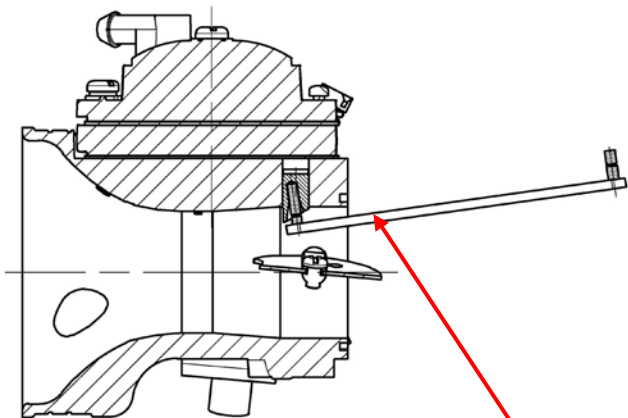

**No Pass Side - OK**  
**Pas de passe côté - Conforme**



**ATT.035 / 19**

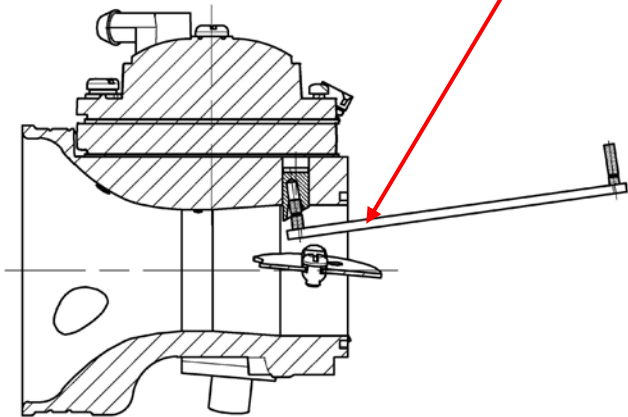

## EXHAUST MANIFOLD CHECKING TOOL - CONTRÔLE DU RACCORD D'ÉCHAPPEMENT

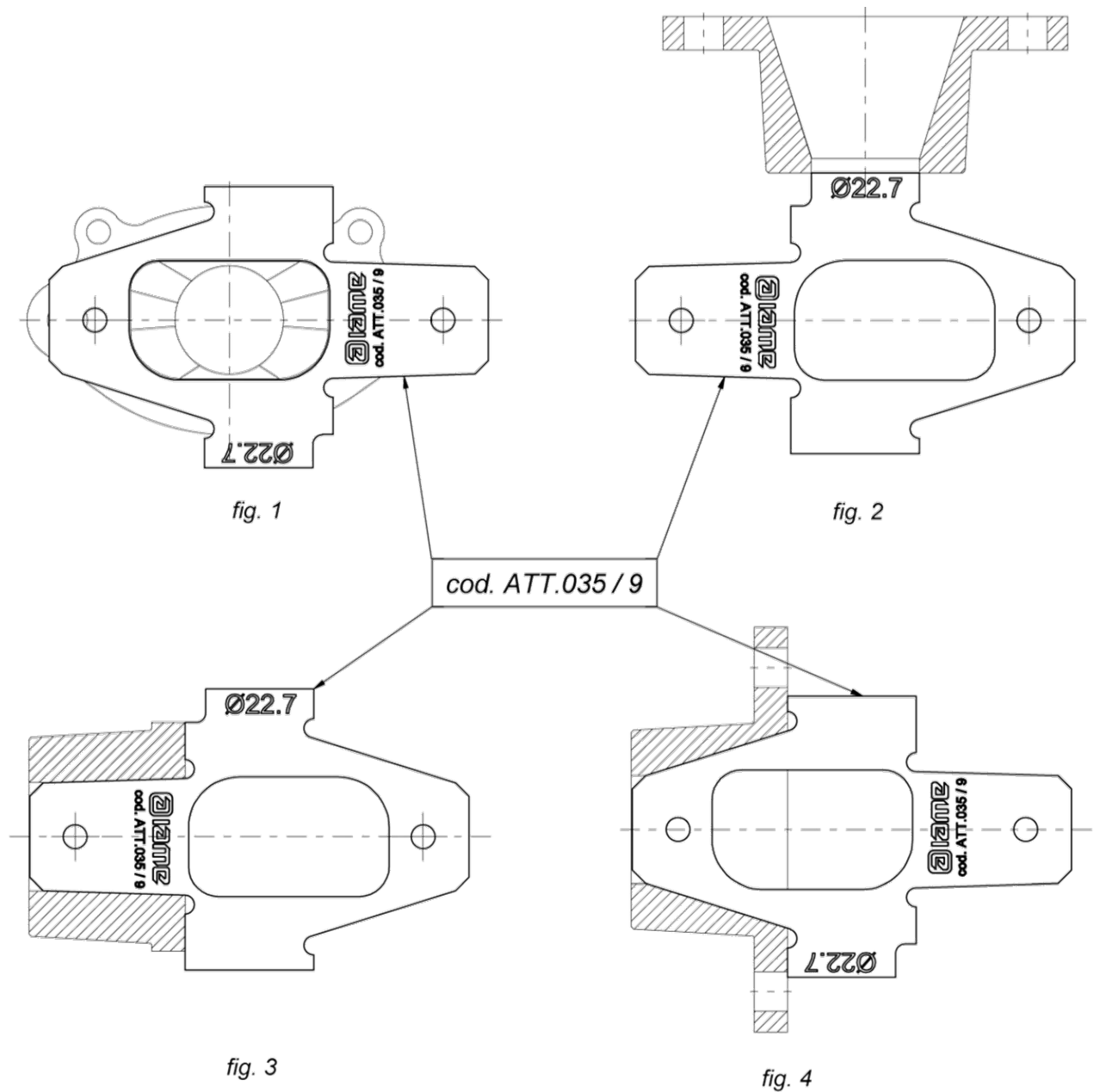

THE NO-GO GAUGE MUST NOT ENTER INTO THE EXHAUST RESTRICTOR, (FIG.2);  
VERIFIEZ QUE LE CALIBRE N'ENTRE PAS DANS LE TROU DU RESTRICTEUR D'ÉCHAPPEMENT.

CHECK THAT THE TOOL MATCHES THE SHAPE OF THE EXHAUST MANIFOLD, (FIG.1,3 AND 4).  
VERIFIEZ QUE LA FORME DU RESTRICTEUR D'ÉCHAPPEMENT EST LA MEME QUE L'OUTIL